

# Arduino Basic Connections

Light a LED.....	5
One LED.....	6
Two LEDs.....	7
Bicolor LED.....	8
Cluster.....	9
Luxeon.....	10
Multiple Cluster or LED strip.....	11
Decoder/Demultiplexer 74HC238.....	12
RGB (Common Cathode).....	13
RGB (Common Anode).....	14
LED strip.....	15
Decade Counter(4017).....	16
Charlieplexing.....	17
LED Array.....	18
Shift Register 74HC595.....	19
Connect multiple 74HC595.....	20
Controlling LED matrix displays with the MAX7219.....	21
Connect Multiple MAX7219.....	22
TLC5940.....	23
Connect multiple TLC5940.....	24
Pushbutton to GND.....	25
Pushbutton to 5V.....	26
Using Internal pullup.....	27
Pushbutton to 12V.....	28
Simple Debouncer.....	29
Debouncing a Pushbutton.....	30
Multiple Buttons (using 1 analog input).....	31
Emulating button presses.....	32
Optocoupled Input.....	33
Pushbutton to 3V3 tolerant pins.....	34
Connect an encoder (internal pullup).....	35

Connect an encoder .....	36
Debouncing a Rotary Encoder .....	37
Connect a Keypad .....	38
Connect a Keypad (with interrupt) .....	39
Connect a Keypad (using 1 analog input) .....	40
Keypad .....	41
Conect a PS2 device .....	42
Keyboard scan codes.....	43
Optocoupled Input (AC Input) .....	44
A simple water level sensor .....	45
A simpe rain sensor.....	46
Connect a Thumbwheel switch.....	47
Connect a Potentiometer (or Trimmer).....	48
Connect a Photoresistor .....	49
Connect a Rotary switch .....	50
Connect a Rotary switch (using 1 analog input) .....	51
Connect a Diverter .....	52
Connect a Diverter (using 1 analog input) .....	53
A water level sensor.....	54
Multiplexing 8 potentiometers .....	55
Connect 8 difital inputs via SPI.....	56
Connect multiple 74HC165 .....	57
Connect a Digital Potentiometer (MCP4161) .....	58
Use a Photoresistor as digital ON/OFF signal .....	59
Connect a DS Touchscreen.....	60
Connect a Relay.....	61
Conect a Relay (Optoisolated) .....	62
Connect a Lamp (DC LOW Voltage) .....	63
Connect a Mosfet.....	64
Connect a DC Motor .....	65
Connect a Solenoid .....	66
Connect a Computer Fan (3 Wire) .....	67
Connect a Computer Fan (4 Wire) .....	68
Buffer Out .....	69

Connect a DAC .....	70
Connect a CT Sensor .....	71
current Sensor.....	72
Measuring DC current (With LT1495) .....	73
Voltage Measurement .....	74
Connect a RTD Temperature Sensor.....	75
Connect a LM35 Temperature Sensor .....	76
Connect a LM35 Temperature Sensor (Full range scale application) .....	77
Connect a TMP36 Temperature Sensor .....	78
Connect a DS18B20 Digital Temperature Sensor.....	79
Connect a MCP9600 Temperature Sensor.....	80
Connect a Thermocouple.....	81
Connect a Gas Sensor .....	82
A Vibration Sensor.....	83
Connect a DHT11 Temperature & Humidity Sensor .....	84
A Sound Sensor .....	85
Connect a Buzzer.....	86
Connect a Buzzer (With Transistor) .....	87
A 1 transistor Audio Amplifier .....	88
Audio Amplifier .....	89
Connect an Audio Amplifier .....	90
Connect a Microphone .....	91
Connect a Microphone (Advanced) .....	92
Connect to Composite Video .....	93
Connect to VGA.....	94
Zero crossing detect.....	95
Connect a Triac .....	96
Connect a Servo .....	97
Connect a IR Sensor .....	98
Connect a IR Emitter .....	99
Bi-Directional Voltage Level Converter 33V to 5V .....	100
Bi-Directional Voltage Level Converter 33V to 5V (with Voltage Divider) .....	101
A simple TTL/CMOS Converter .....	102
TTL/CMOS Converter (6 Ports).....	103

Connect a SD Card (Simple) .....	104
Connect a SD Card (Advanced) .....	105
SD Card Pinout .....	106
A Simple Serial interface .....	107
RS232 Pinout .....	108
Connect 2 MPU's.....	109
Protect a I/O Pin.....	110
MDI Interface .....	111
A simple DMX interface .....	112
Driving multiple MIDI Outputs.....	113
Connect a SHARP GP2Y0A21 Distance Sensor .....	114
A simple RS485 Node .....	115
DIY Board .....	116
Simple 5V Power Supply .....	117
Simple 3V3 Power Supply .....	118
Connect a RTC.....	119
Conect a EEPROM .....	120
EEPROM Wiki .....	121
Hitachi 44780 Compatible pinout .....	122
Connect a LED Hitachi 44780 Compatible .....	123
Connect a LED Hitachi 44780 Compatible via 12C.....	124
Control LCD Backlight.....	125
7 segments Display .....	126
Connect a Nokia LCD.....	127



# Light a LED



## Light a LED

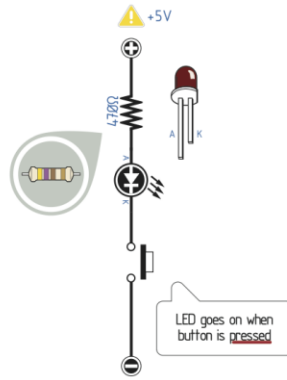

# One LED



# One LED

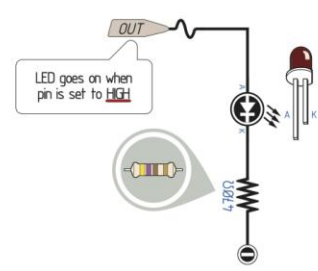
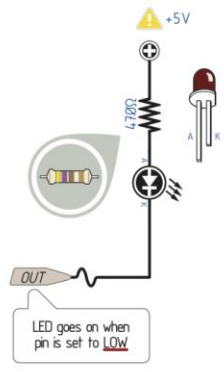

# Two LEDs



## Two LEDs

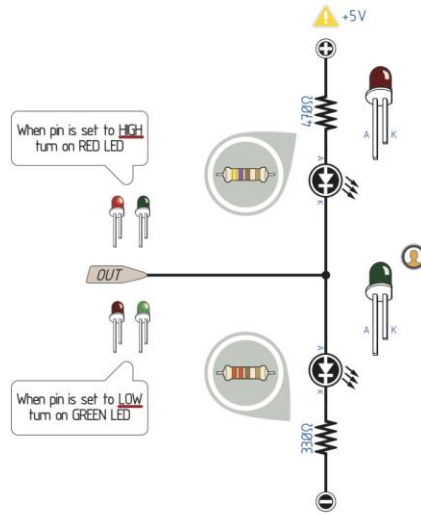

# Bicolor LED



## Bicolor LED

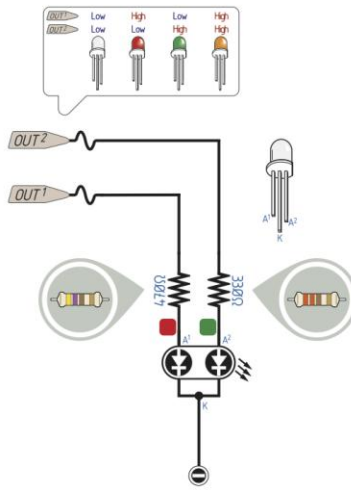

# Cluster



## Cluster

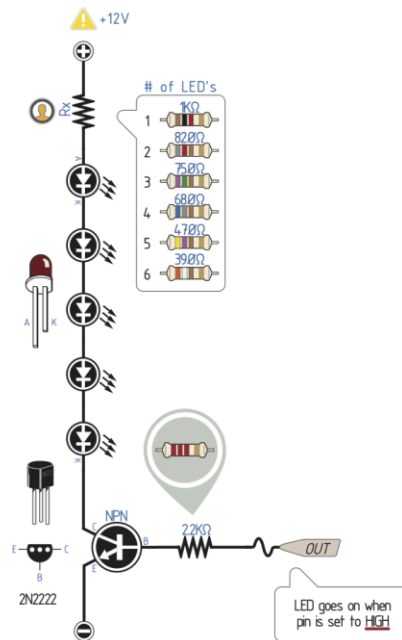

# Luxeon



## Luxeon

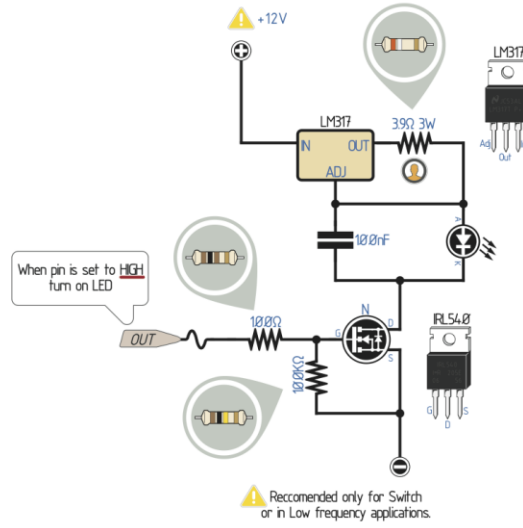

# Multiple Cluster or LED strip



Multiple Cluster or LED strip

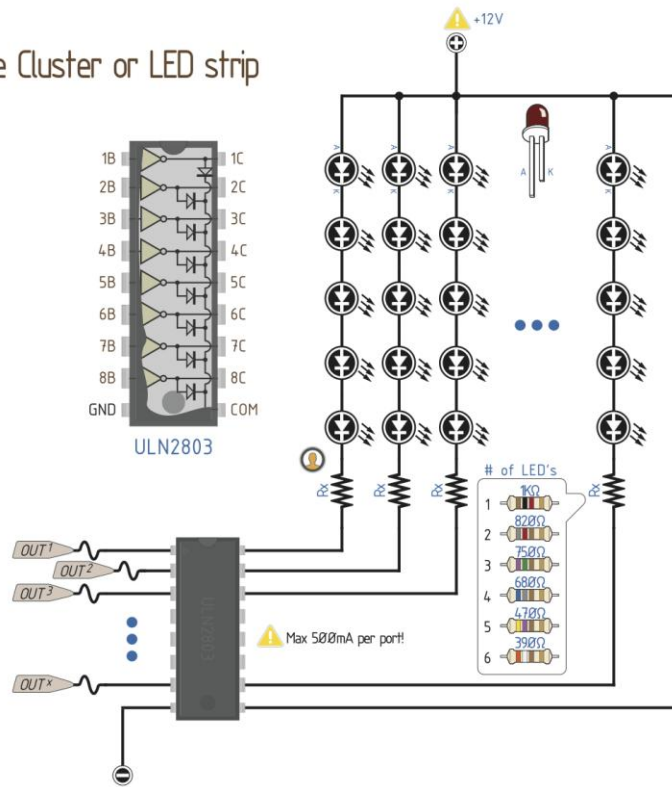

# Decoder/Demultiplexer 74HC238



## Decoder/Demultiplexer 74HC238

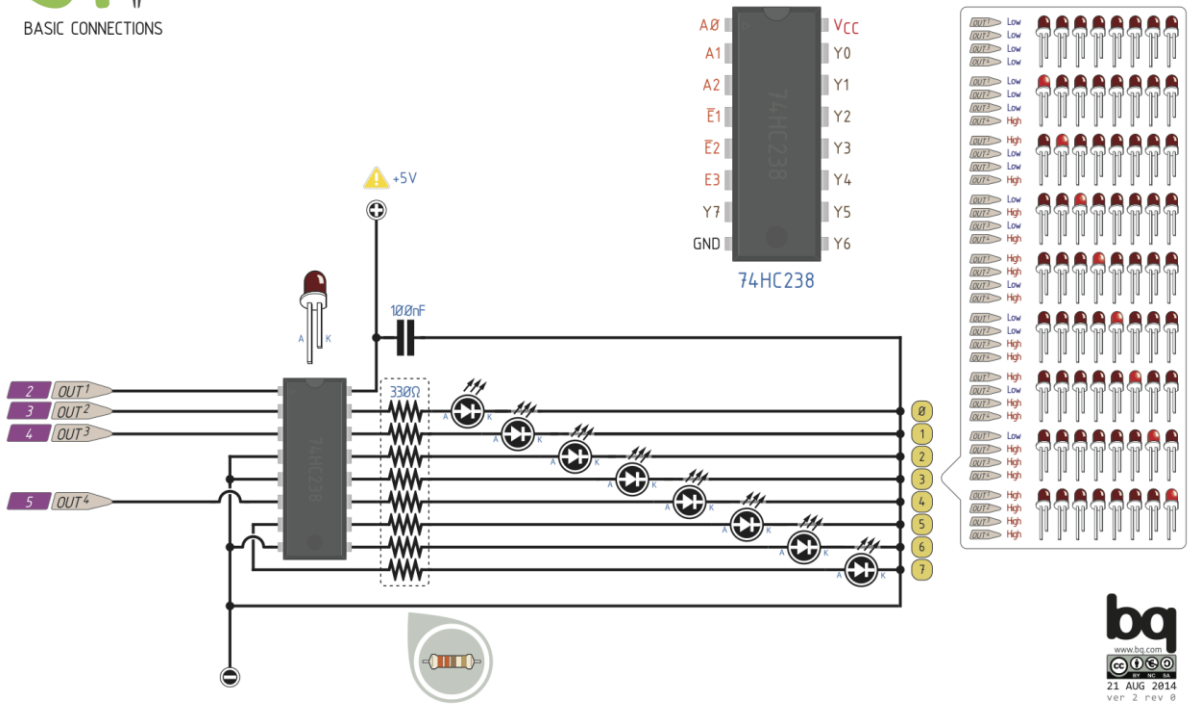



# RGB (Common Cathode)



RGB (common Cathode)

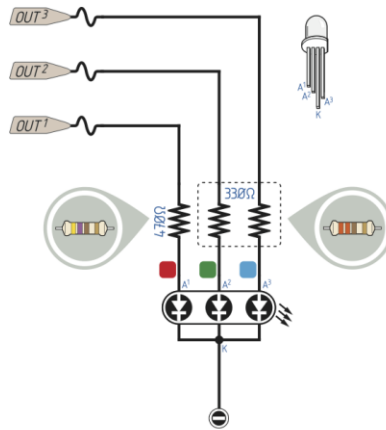

# RGB (Common Anode)



RGB (common Anode)

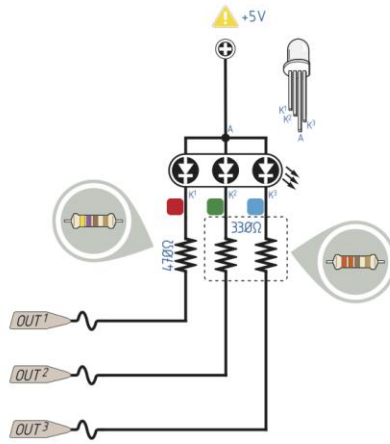

# LED strip



## LED Strip

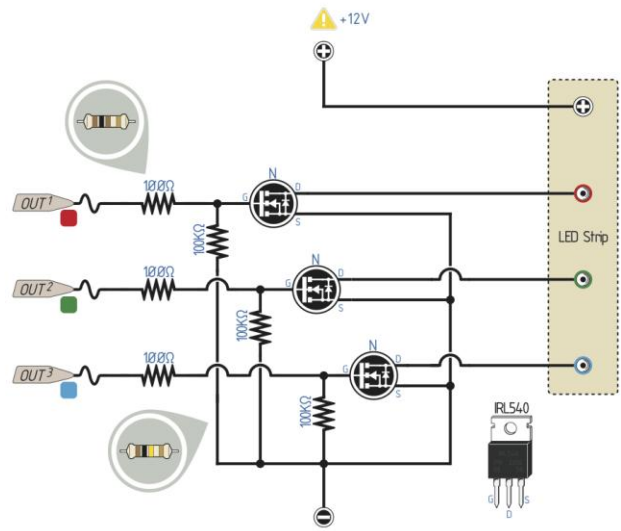

# Decade Counter(4017)

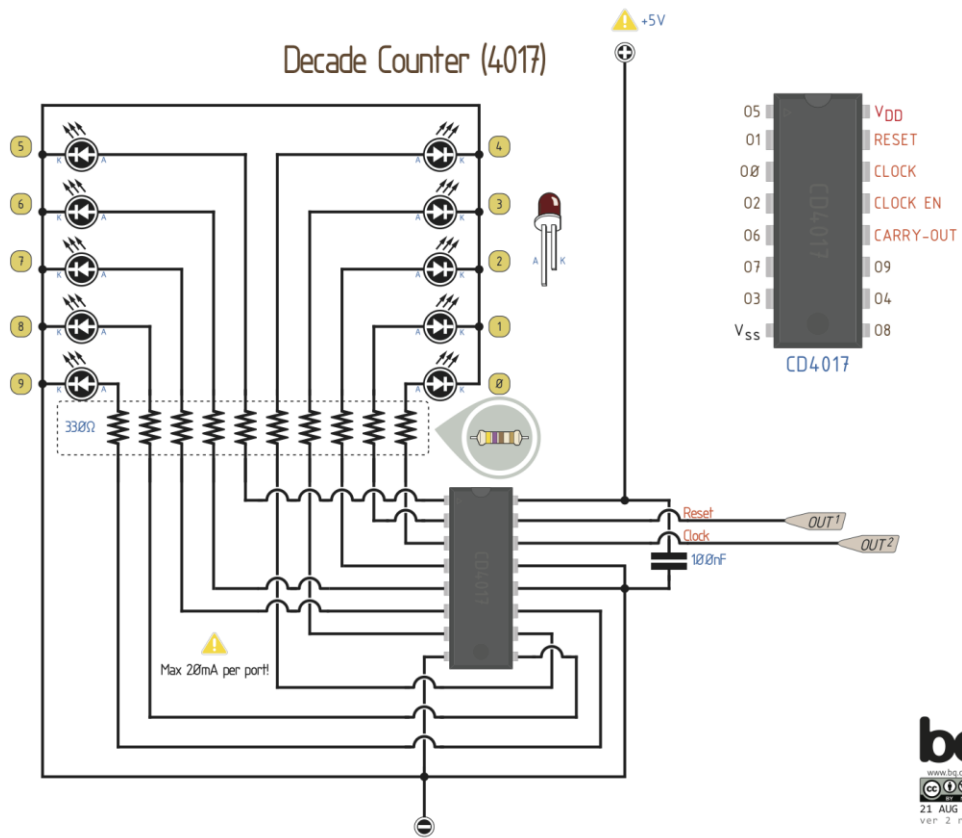

# Charlieplexing



## Charlieplexing

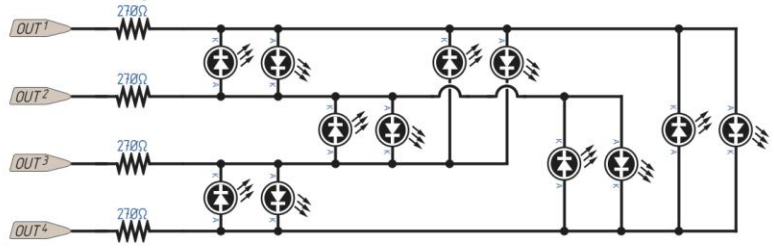
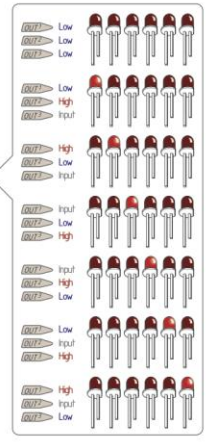
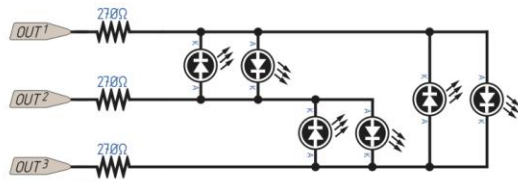

# LED Array



LED Array

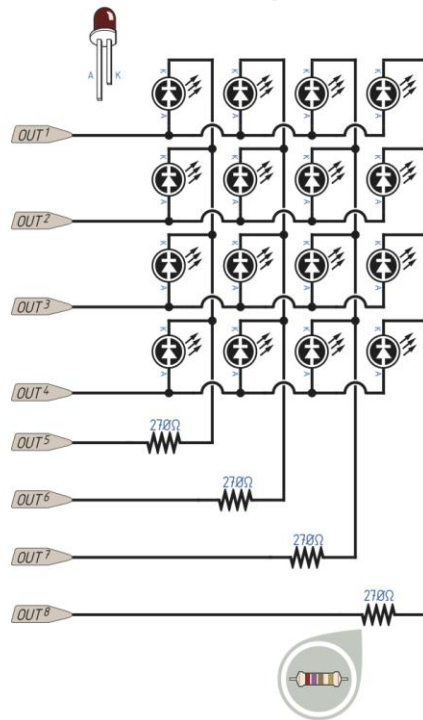



# Connect multiple 74HC595



## Connect multiple 74HC595

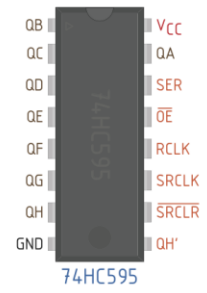
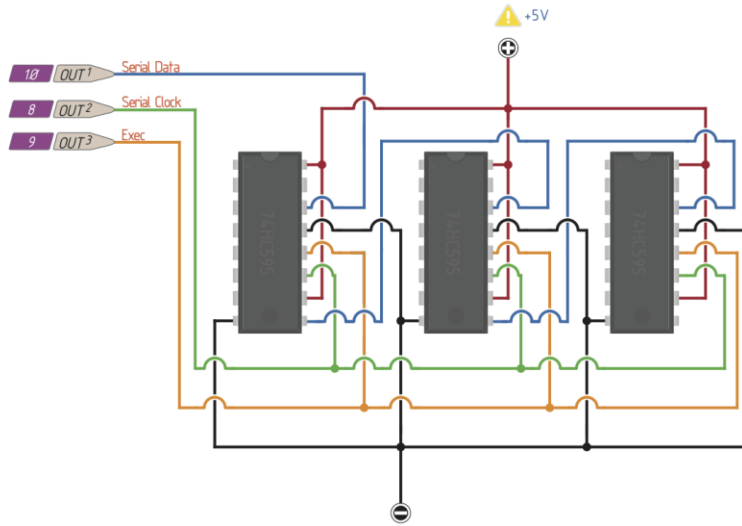



# Controlling LED matrix displays with the MAX7219



Controlling LED matrix displays with the MAX7219

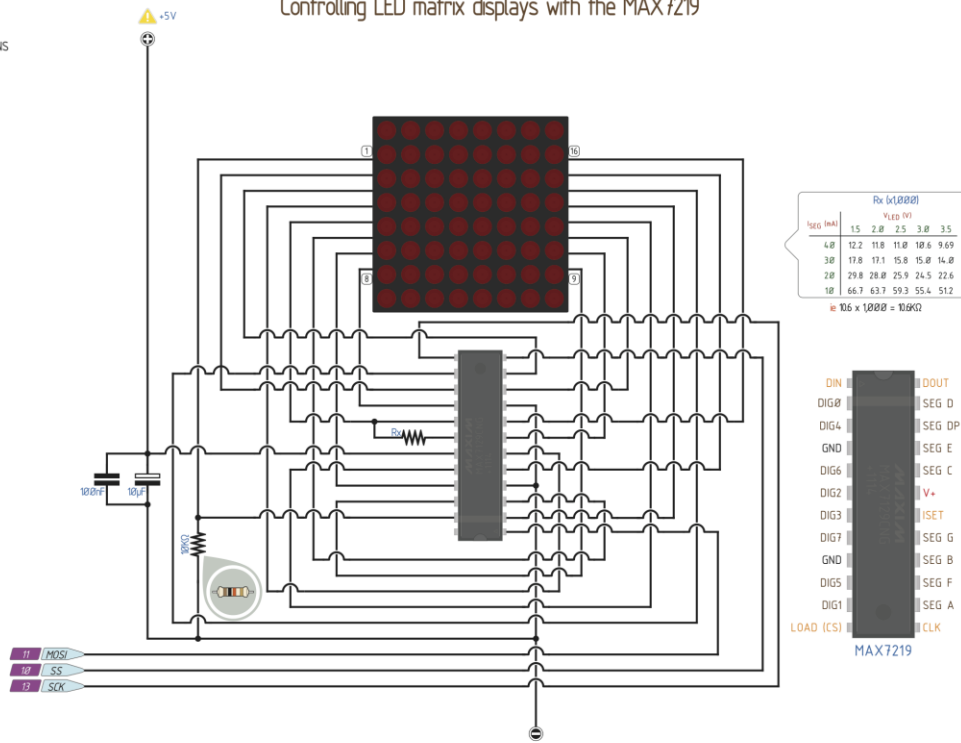

# Connect Multiple MAX7219



Connect multiple MAX7219

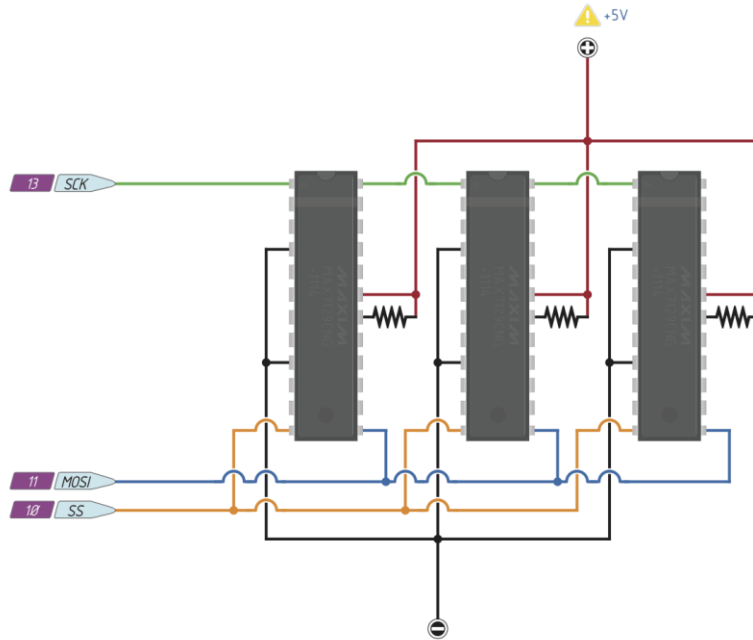

# TLC5940



TLC5940

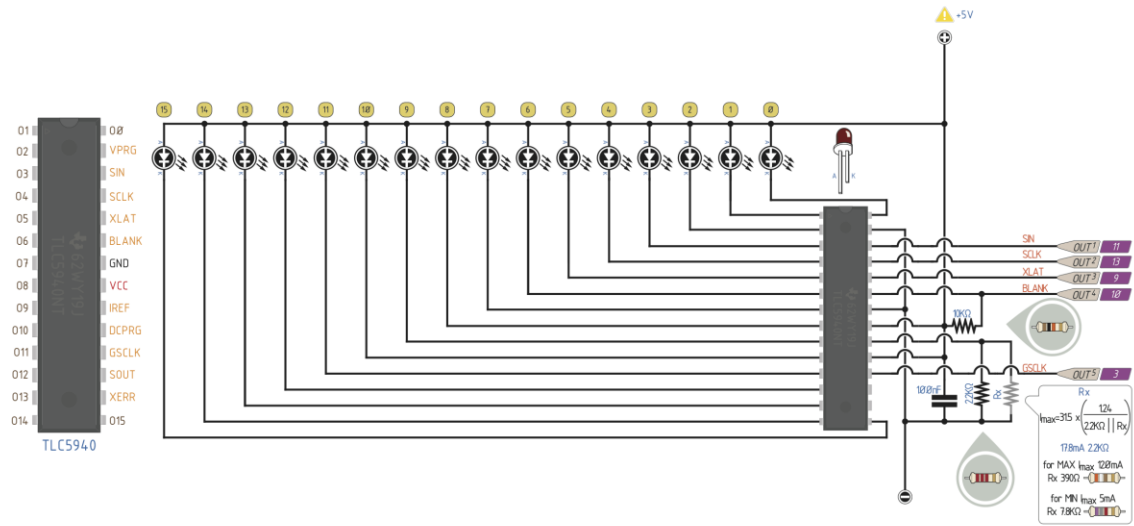

# Connect multiple TLC5940



Connect multiple TLC5940

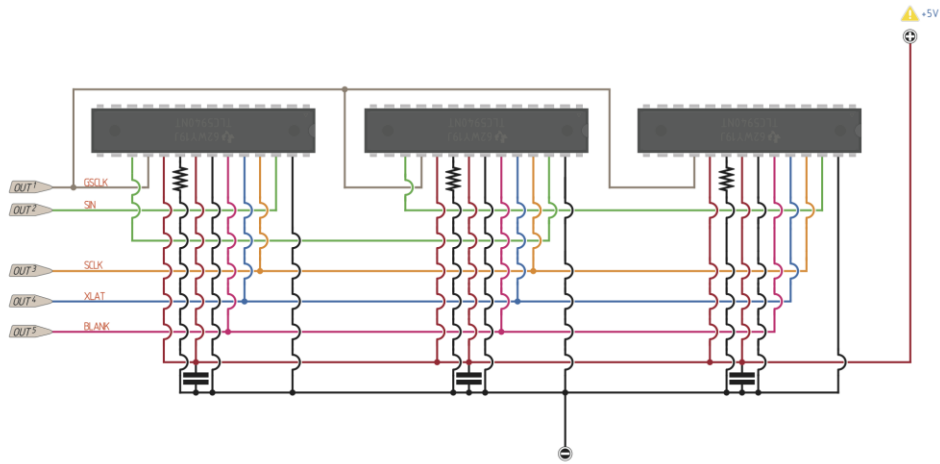

## Pushbutton to GND



## Pushbutton to GND

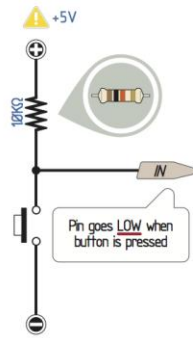

## Pushbutton to 5V



## Pushbutton to 5V

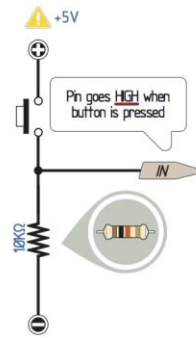

## Using Internal pullup



## Using Internal pullup

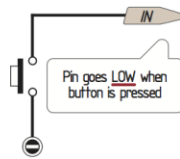

# Pushbutton to 12V



## Pushbutton to 12V

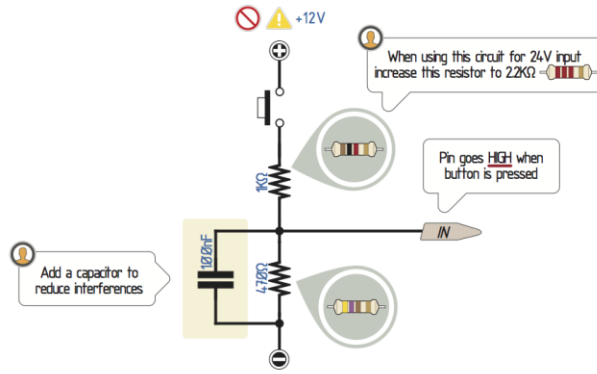



# Simple Debouncer



## Simple Debouncer

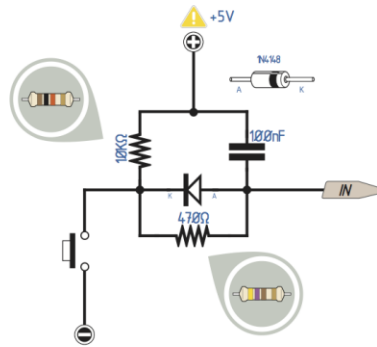

# Debouncing a Pushbutton



## Debouncing a Pushbutton

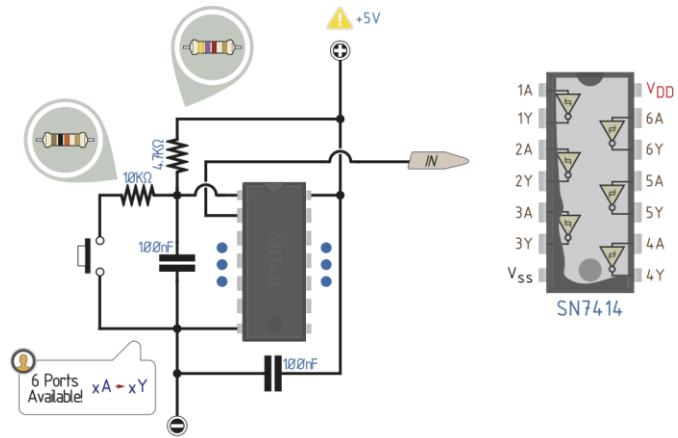

## Multiple Buttons (using 1 analog input)



### Multiple Buttons (using 1 analog input)

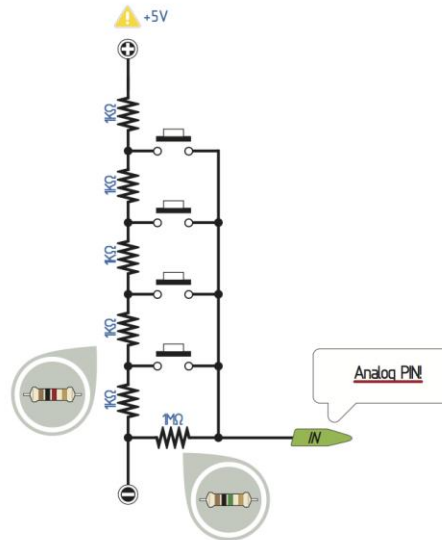

# Emulating button presses



## Emulating button presses

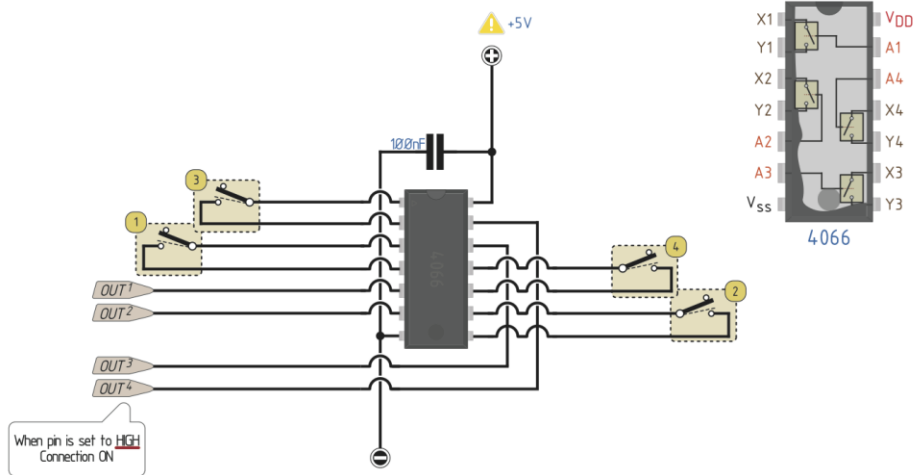

# Optocoupled Input



## Optocoupled Input

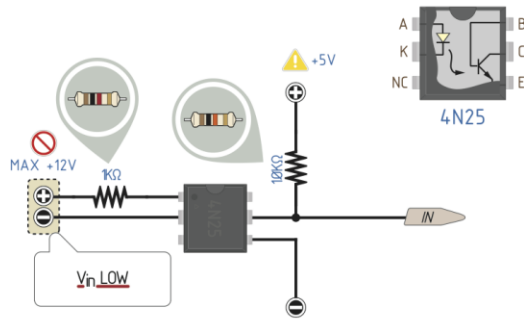

## Pushbutton to 3V3 tolerant pins



### Pushbutton to 3V3 tolerant pins

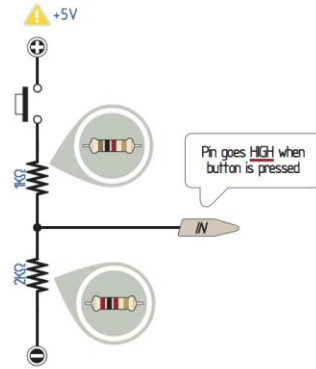

## Connect an encoder (internal pullup)



Connect an encoder (internal pullup)

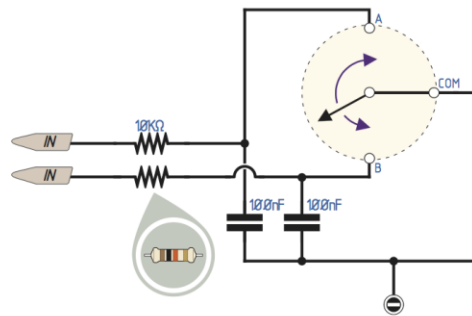

## Connect an encoder



## Connect an encoder

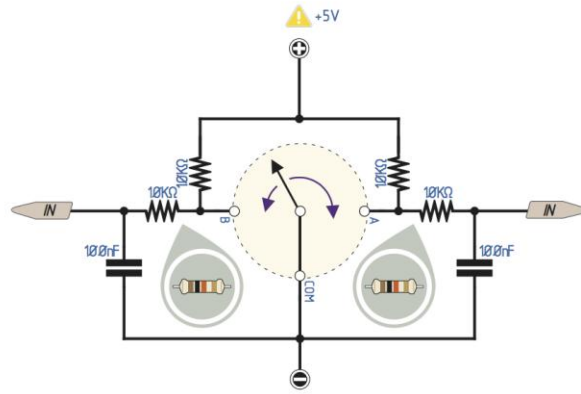



# Debouncing a Rotary Encoder



## Debouncing a Rotary Encoder

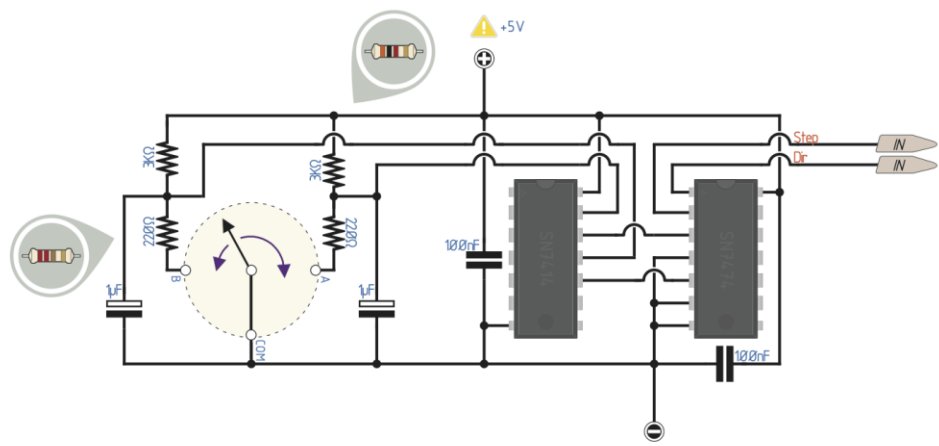
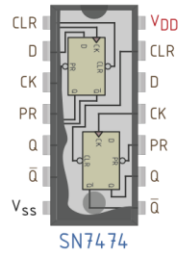
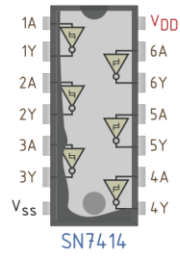

# Connect a Keypad



## Connect a Keypad

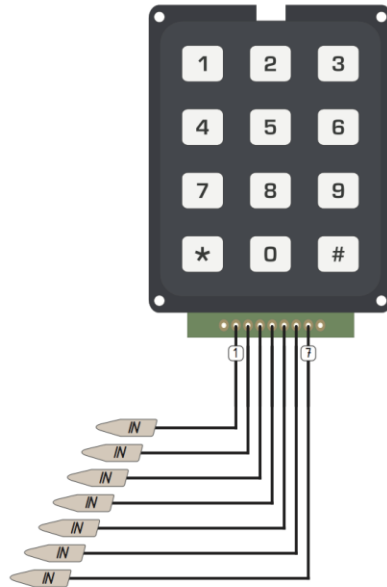



## Connect a Keypad (using 1 analog input)



### Connect a Keypad (using 1 analog input)

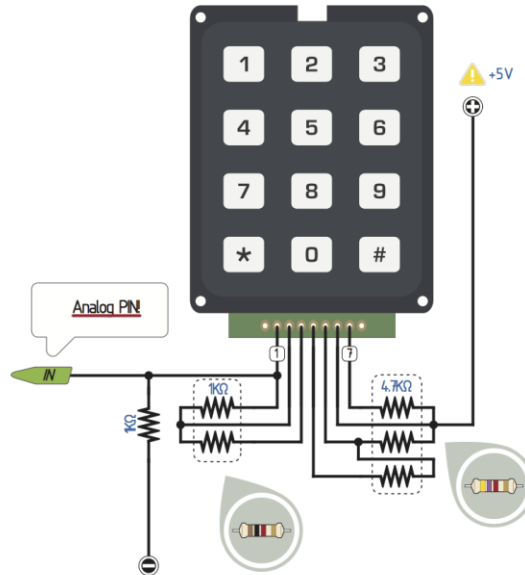

# Keypad



## Keypad

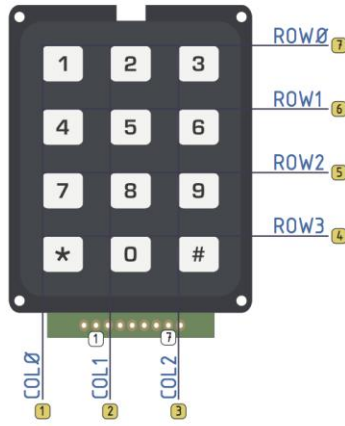

## Conect a PS2 device



## Connect a PS2 device

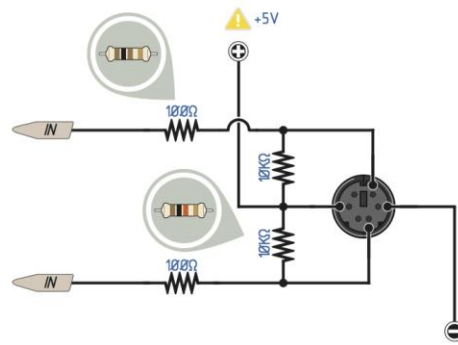

# Keyboard scan codes



## Keyboard scan codes

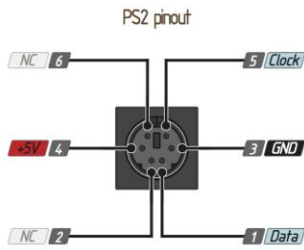

# Optocoupled Input (AC Input)



## Optocoupled Input (AC Input)

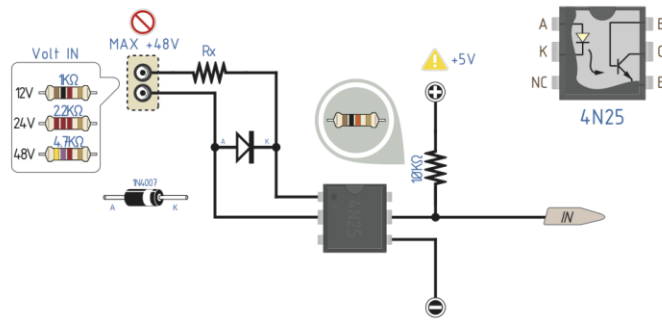



# A simple water level sensor



A simple water level sensor

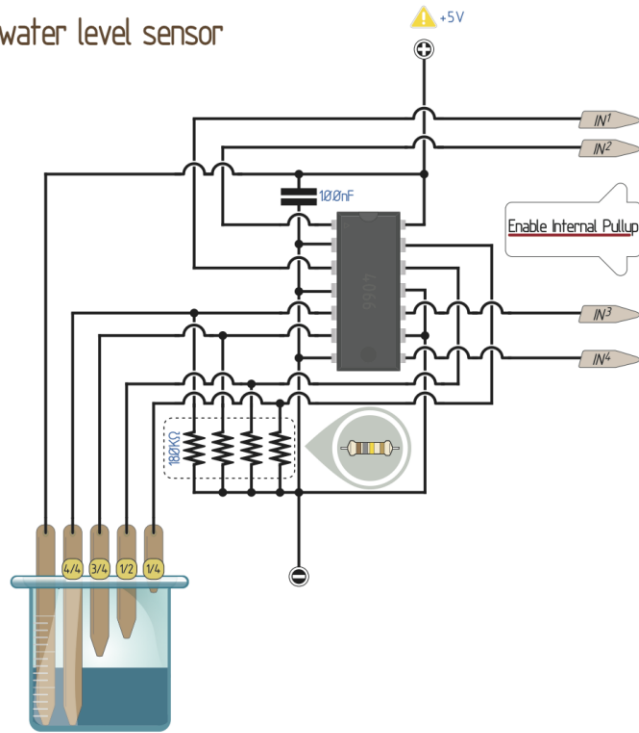

# A simple rain sensor



A simple rain sensor

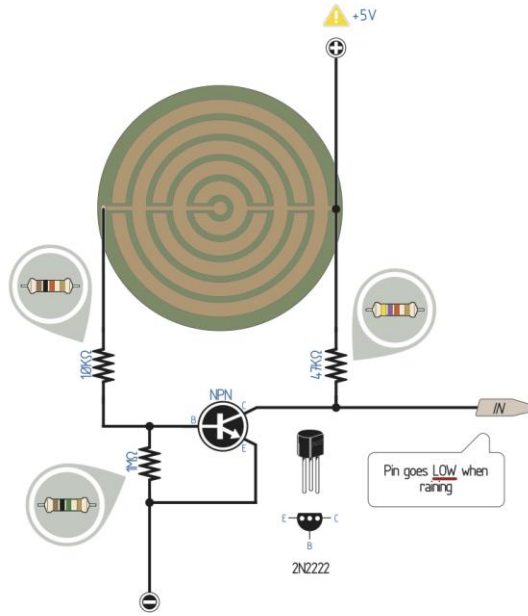

# Connect a Thumbwheel switch



## Connect a Thumbwheel switch

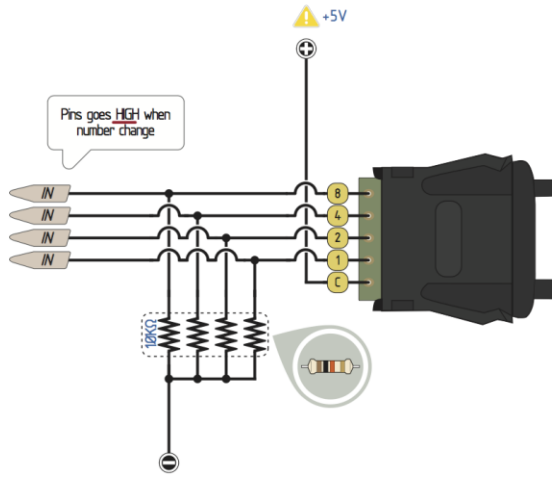

0					5	1	4	
1	1				6	2	4	
2		2			7	1	2	4
3	1	2			8			8
4			4		9	1		8



## Connect a Potentiometer (or Trimmer)



Connect a Potentiometer (or Trimmer)

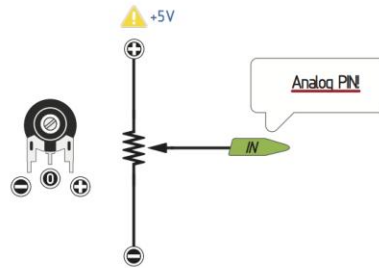

## Connect a Photoresistor



## Connect a Photoresistor

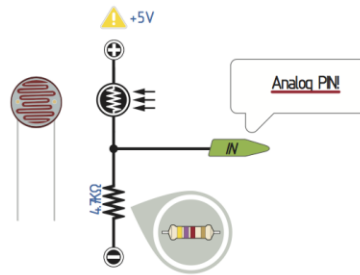

# Connect a Rotary switch



## Connect a Rotary switch

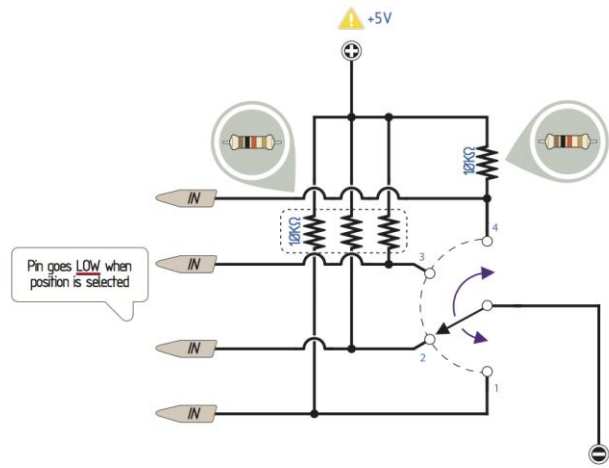

## Connect a Rotary switch (using 1 analog input)



Connect a Rotary switch (using 1 analog input)

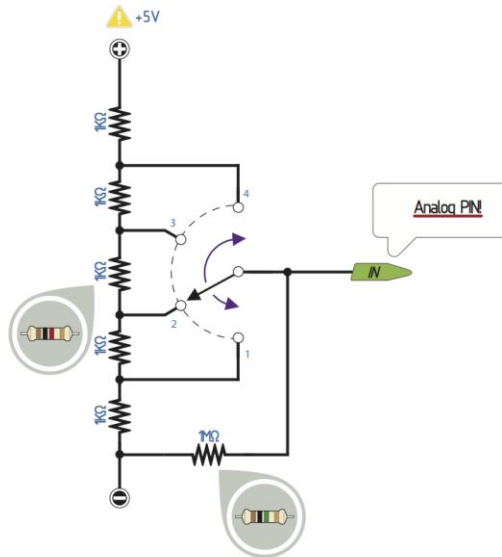

## Connect a Diverter



## Connect a Diverter

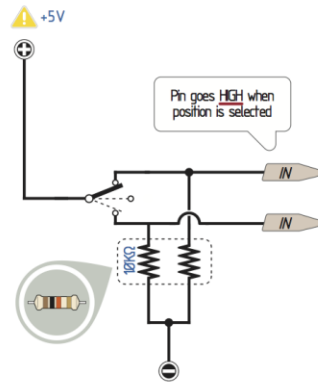



## Connect a Diverter (using 1 analog input)



Connect a Diverter (using 1 analog input)

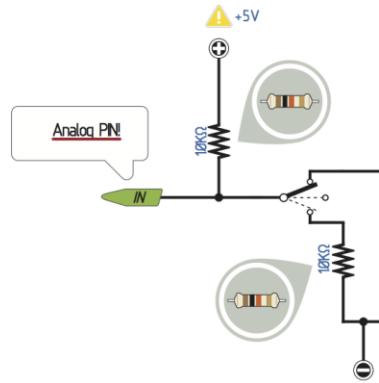

# A water level sensor



## A water level sensor

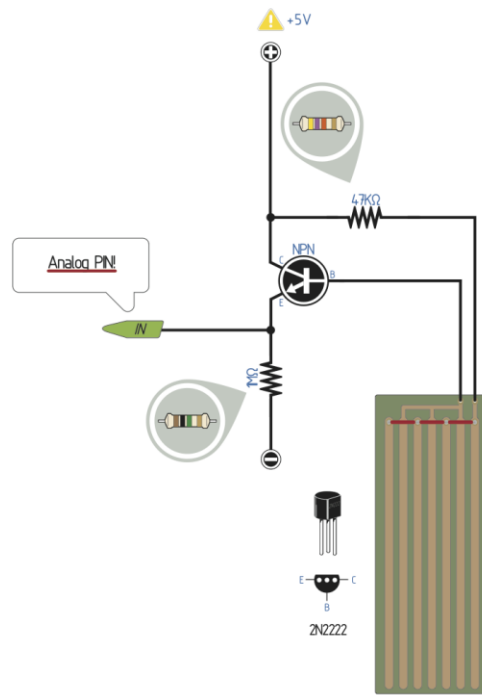

# Multiplexing 8 potentiometers



## Multiplexing 8 potentiometers

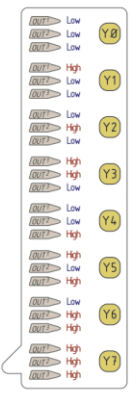
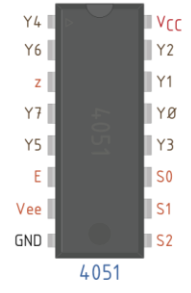
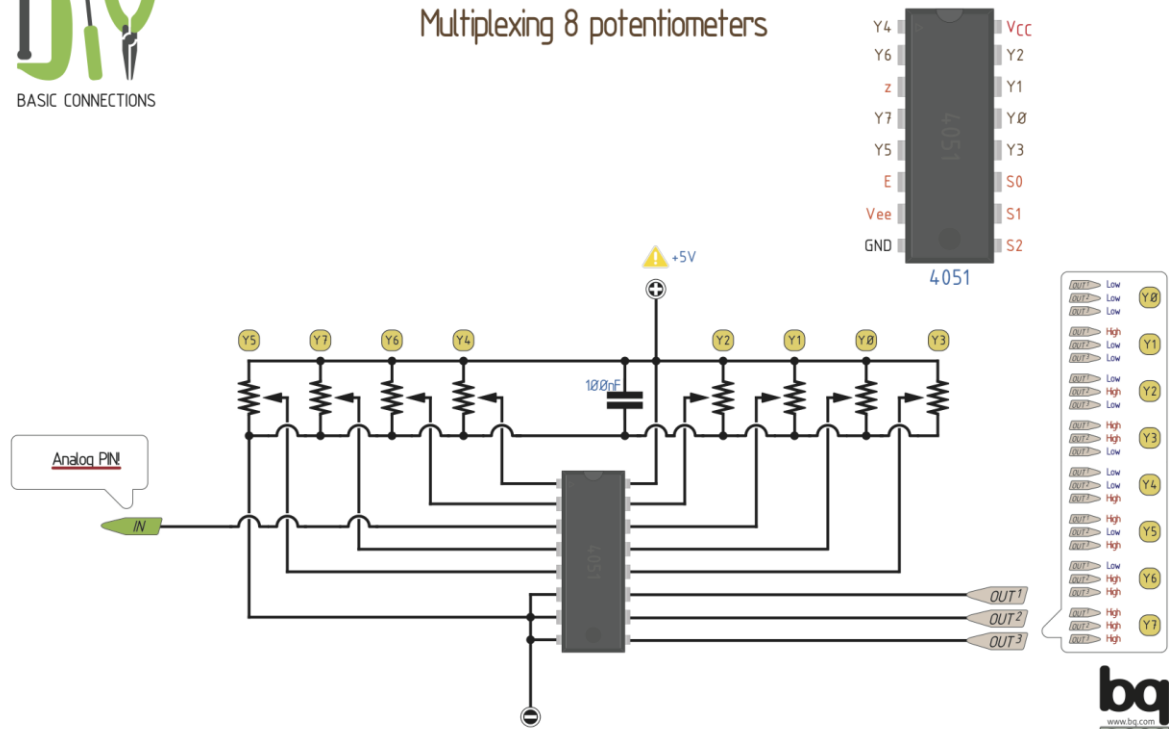

# Connect 8 digital inputs via SPI



## Connect 8 digital inputs via SPI

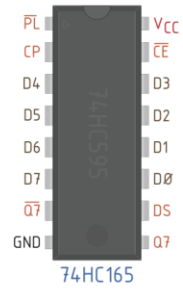
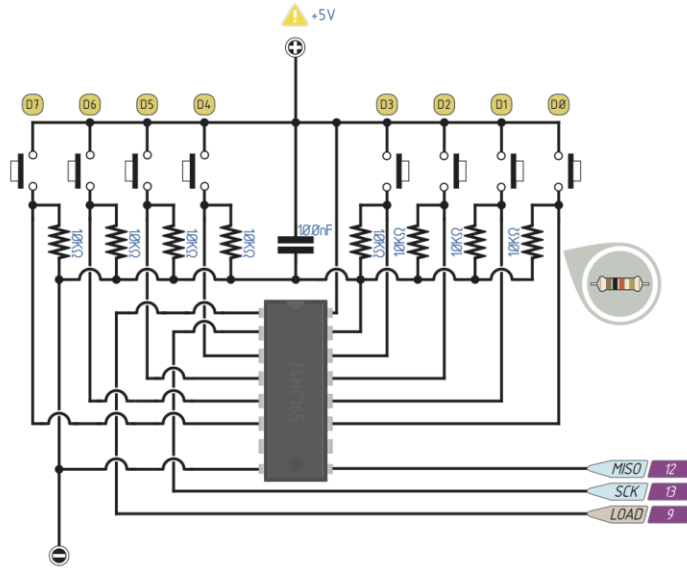

## Connect multiple 74HC165



Connect multiple 74HC165

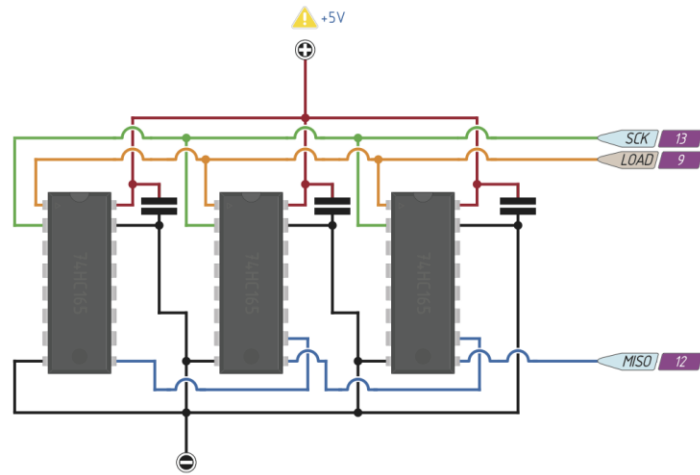

## Connect a Digital Potentiometer (MCP4161)



### Connect a Digital Potentiometer (MCP4161)

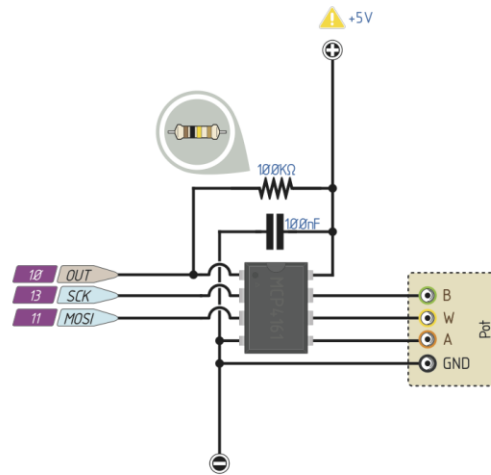

# Use a Photoresistor as digital ON/OFF signal



## Use a Photoresistor as digital ON/OFF signal

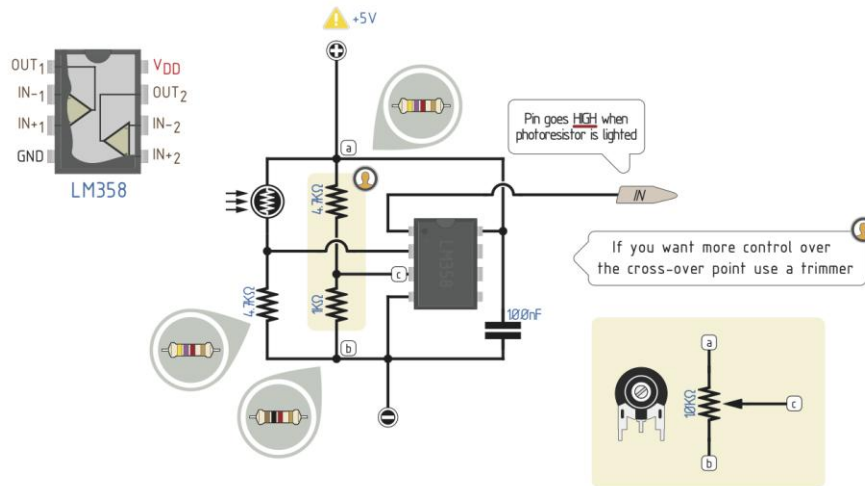

# Connect a DS Touchscreen



## Connect a DS Touchscreen

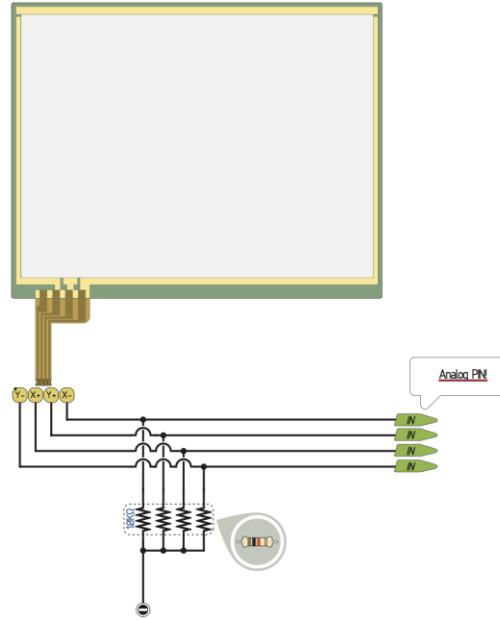



# Connect a Relay



## Connect a Relay

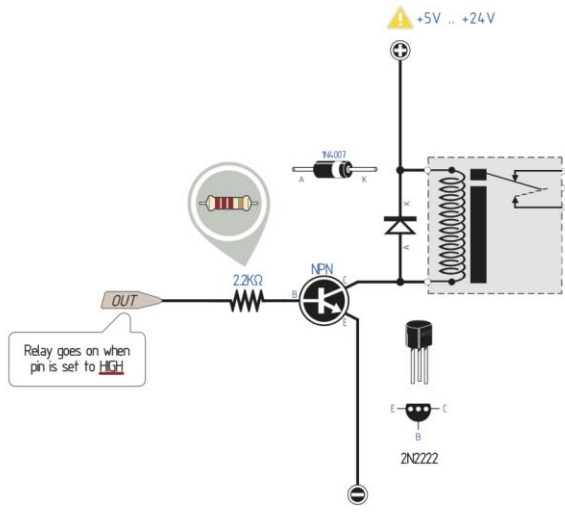

# Connect a Relay (Optoisolated)



## Connect a Relay (Optoisolated)

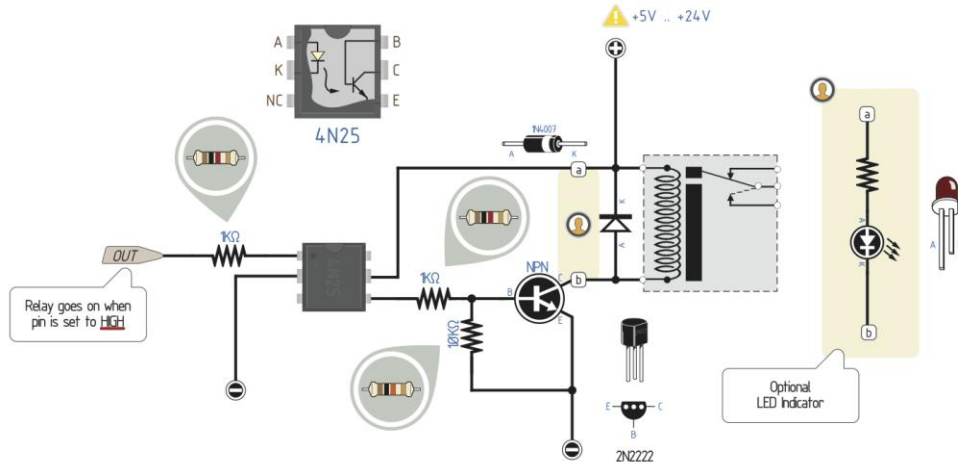

## Connect a Lamp (DC LOW Voltage)



## Connect a Lamp (DC LOW Voltage)

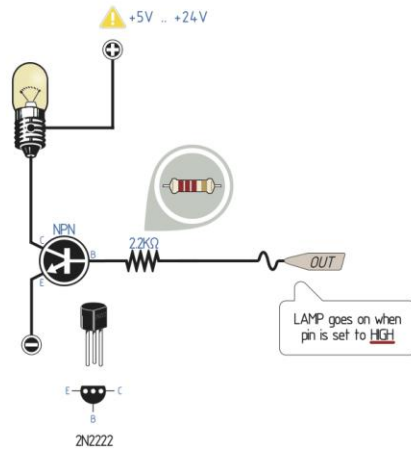

# Connect a Mosfet



## Connect a Mosfet

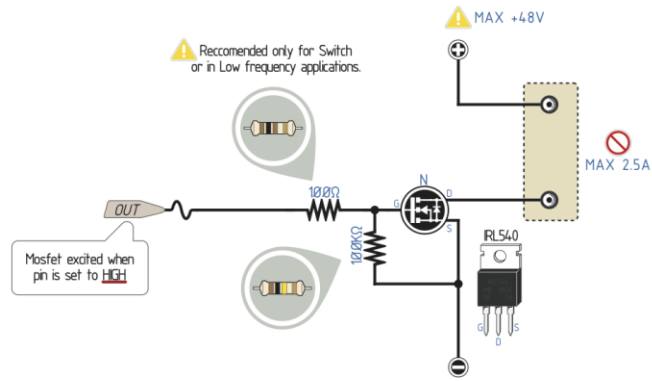

# Connect a DC Motor



## Connect a DC Motor

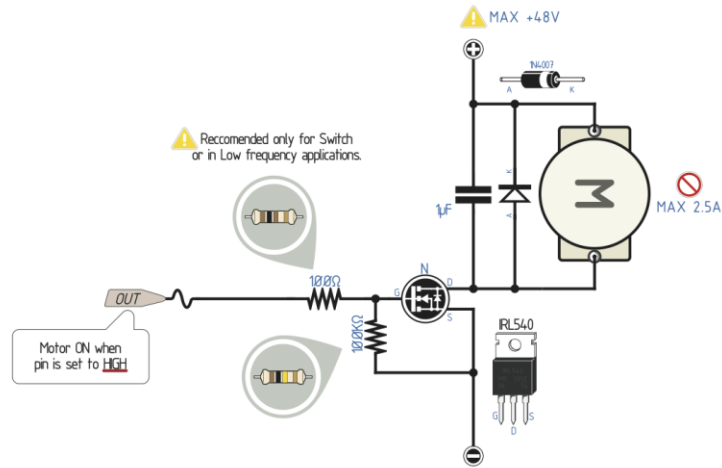

# Connect a Solenoid



## Connect a Solenoid

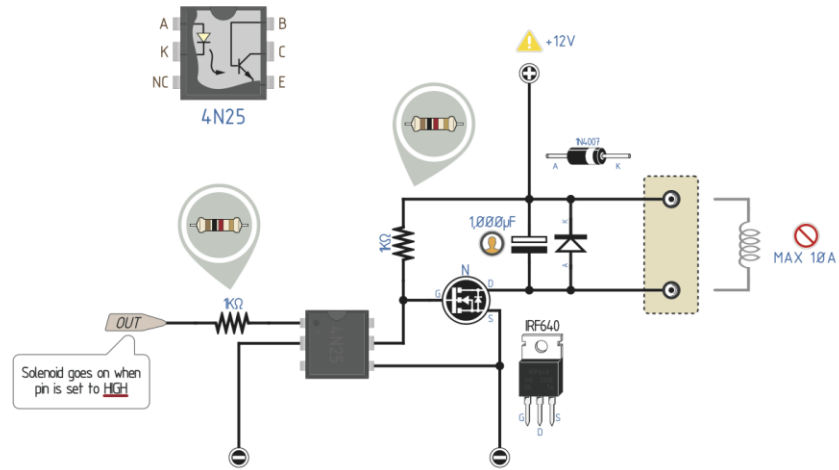

The large electrolytic capacitor is very important, as it is used to help supply the large current draw of the solenoid







# Buffer Out



## Buffer Out

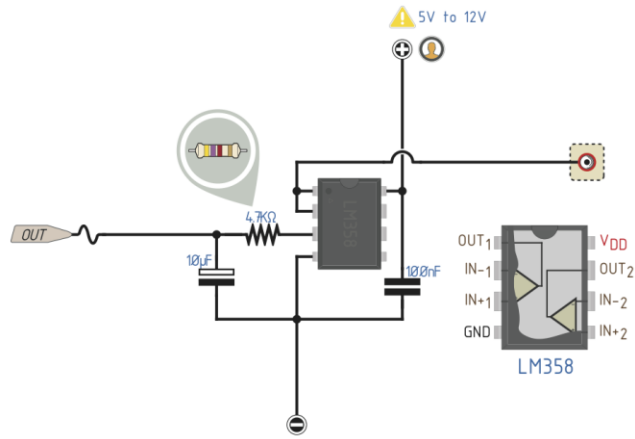

⚠ If supply voltage is 5V it outputs a maximum of about 34V.  
Suggested 7V for 5V output



# Connect a CT Sensor



## Connect a CT Sensor

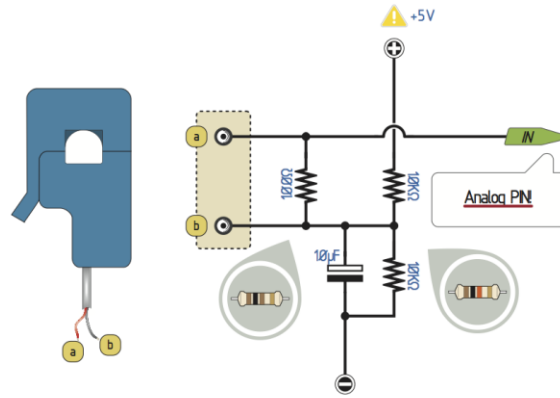

# current Sensor



## Current Sensor

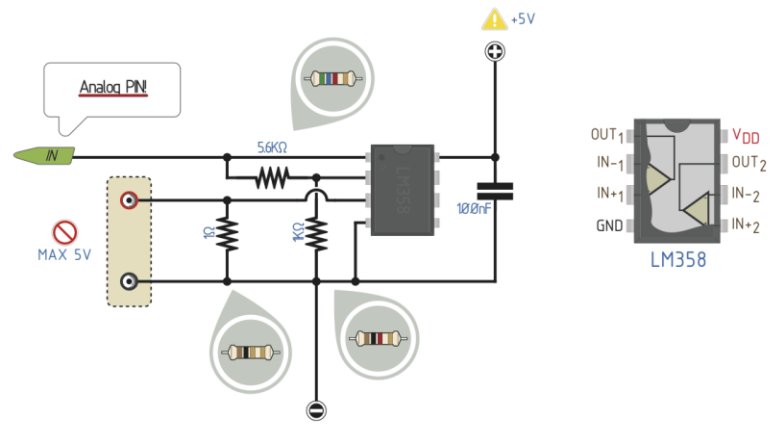

# Measuring DC current (With LT1495)



## Measuring DC current (With LT1495)

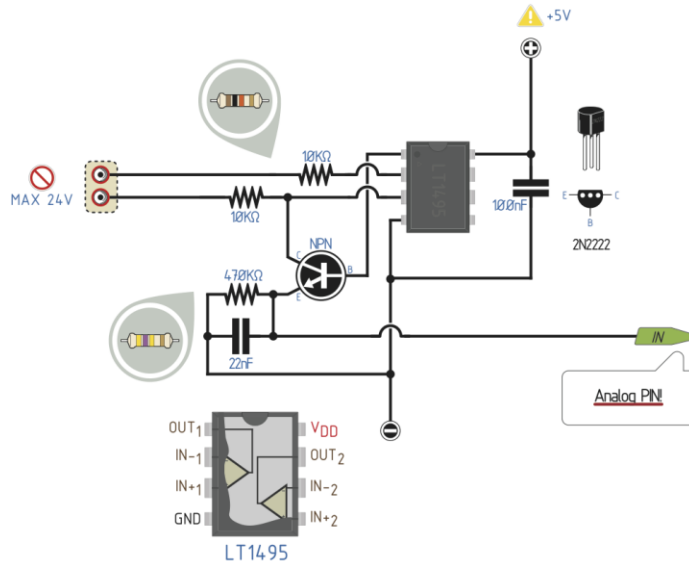

# Voltage Measurement



## Voltage Measurement

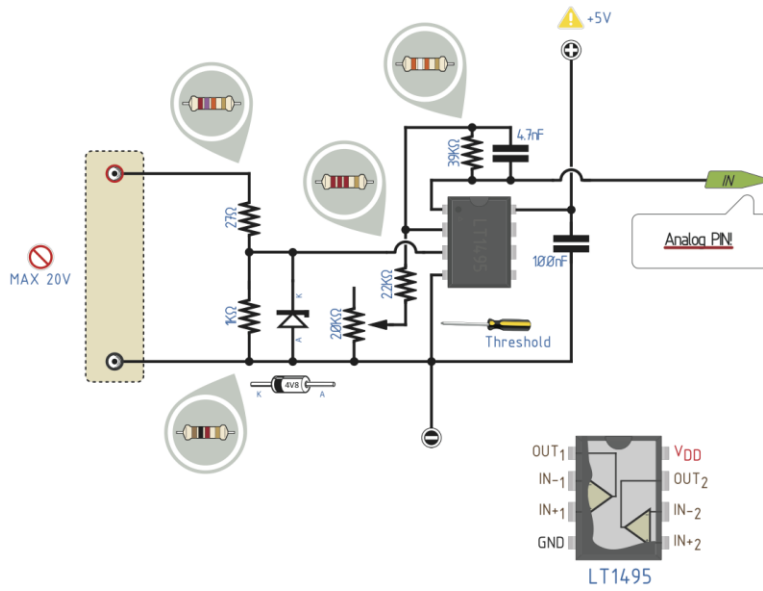

# Connect a RTD Temperature Sensor



## Connect a RTD Temperature Sensor

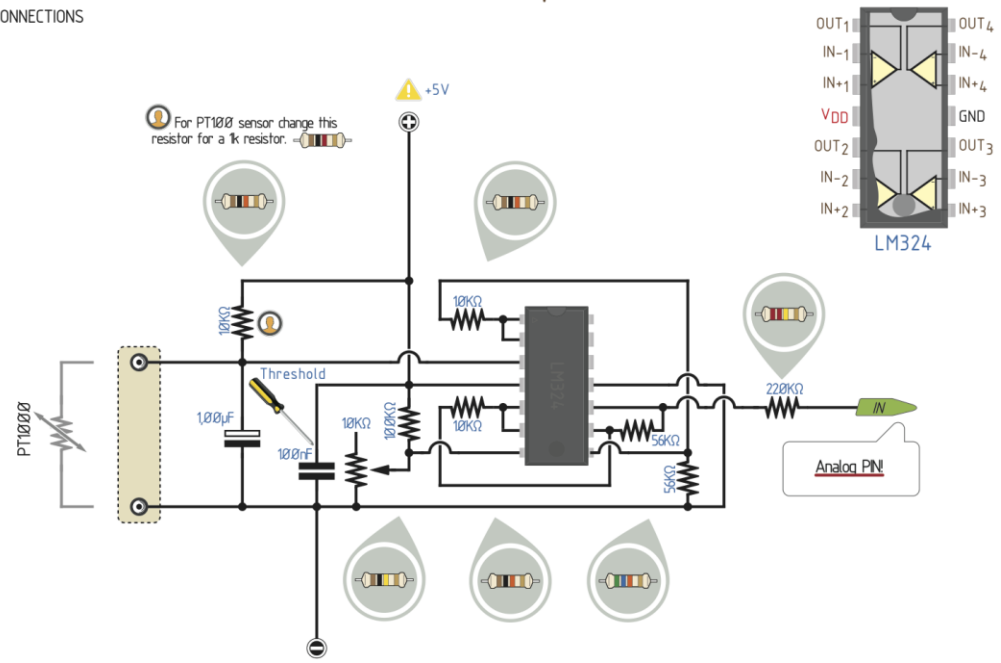

## Connect a LM35 Temperature Sensor



### Connect a LM35 Temperature Sensor

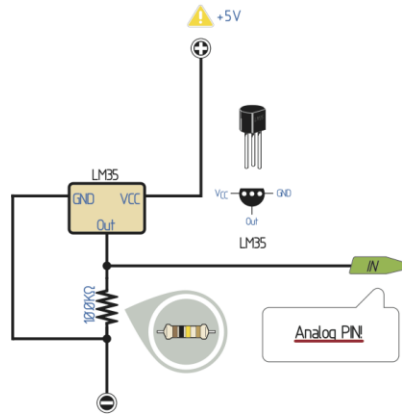



## Connect a LM35 Temperature Sensor (Full range scale application)



### Connect a LM35 Temperature Sensor (Full range scale application)

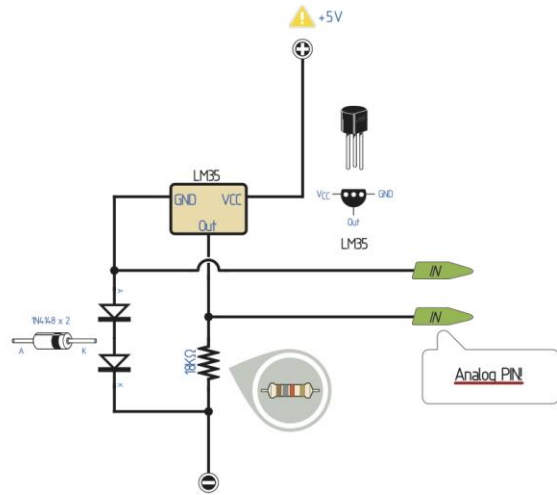

## Connect a TMP36 Temperature Sensor



### Connect a TMP36 Temperature Sensor

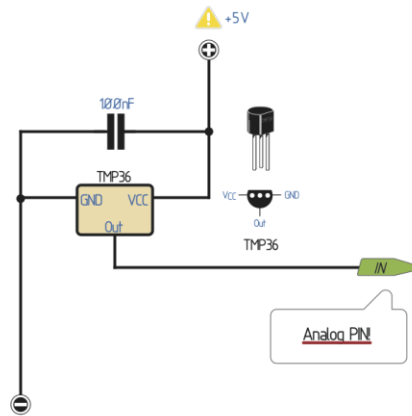

# Connect a DS18B20 Digital Temperature Sensor



## Connect a DS18B20 Digital Temperature Sensor

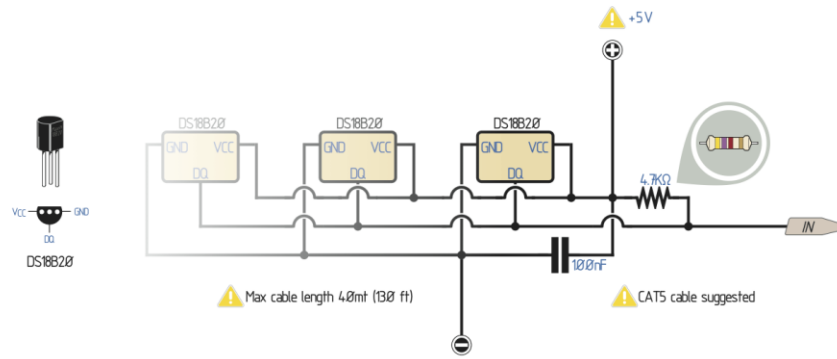

## Connect a MCP9600 Temperature Sensor



### Connect a MCP9600 Temperature Sensor

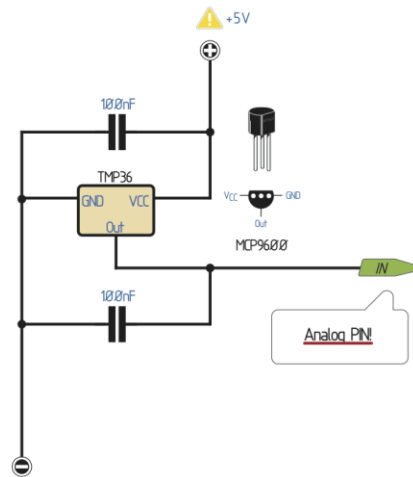

# Connect a Thermocouple



## Connect a Thermocouple

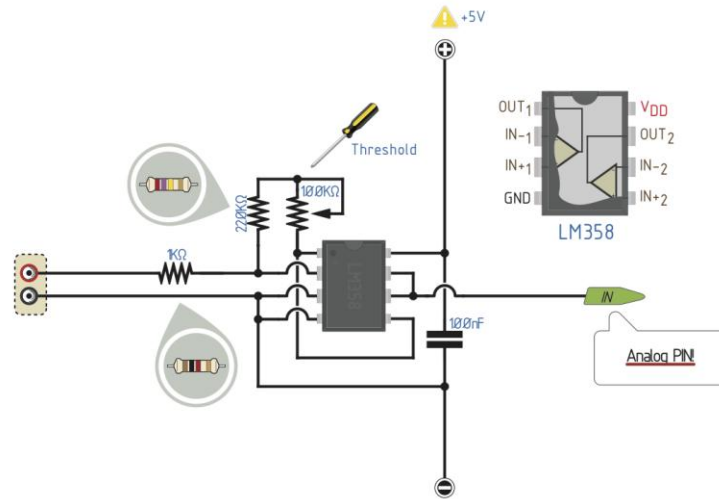

# Connect a Gas Sensor



## Connect a Gas Sensor

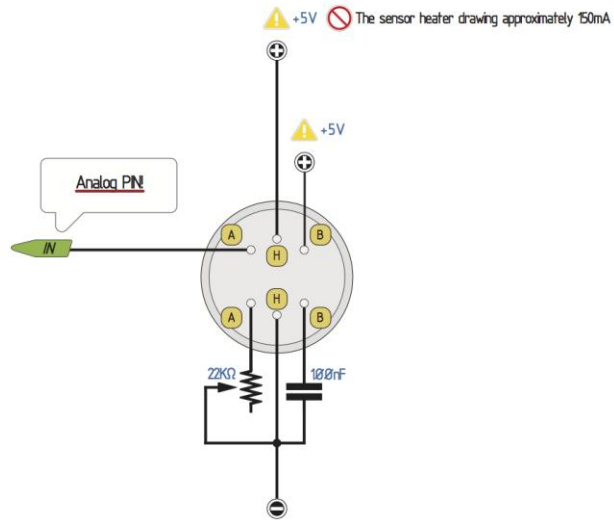



# Connect a DHT11 Temperature & Humidity Sensor



## Connect a DHT11 Temperature & Humidity Sensor

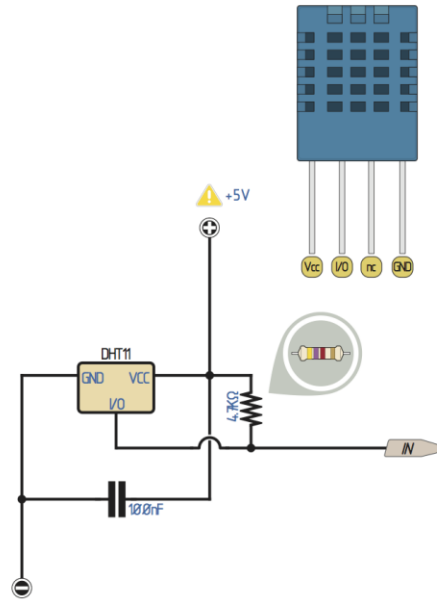



# A Sound Sensor



## A Sound Sensor

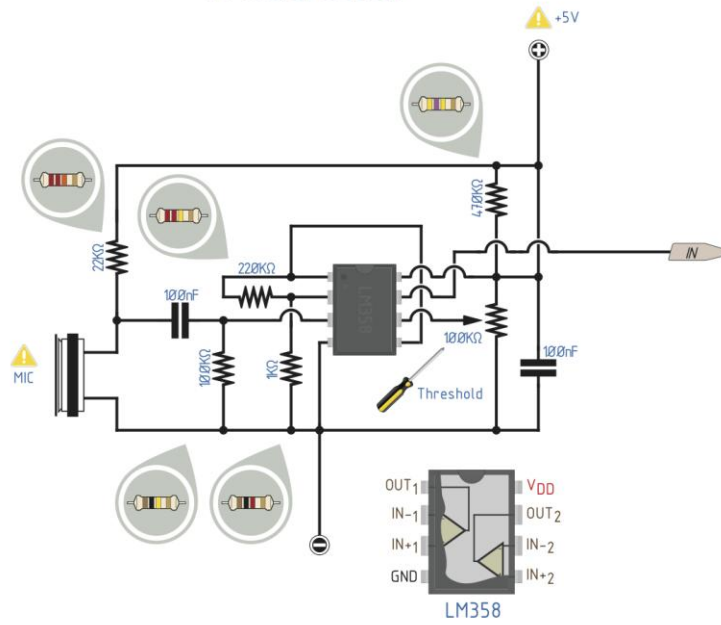

## Connect a Buzzer



## Connect a Buzzer

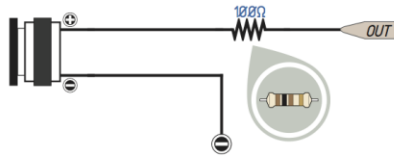

## Connect a Buzzer (With Transistor)



## Connect a Buzzer (With Transistor)

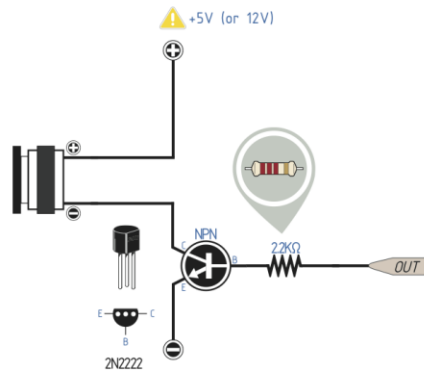

# A 1 transistor Audio Amplifier



## A 1 transistor Audio Amplifier

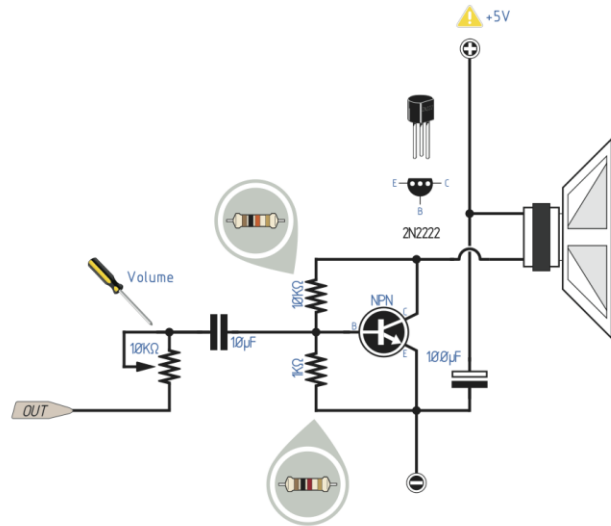

# Audio Amplifier

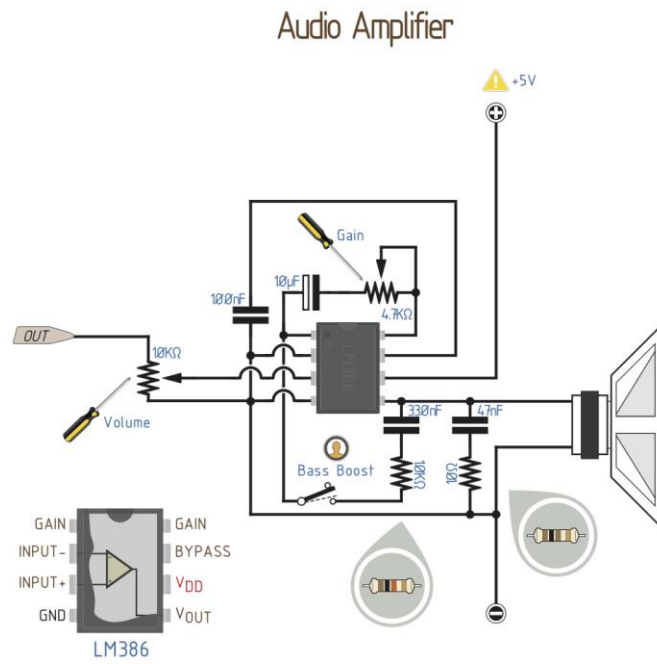

# Connect an Audio Amplifier



## Connect an Audio Amplifier

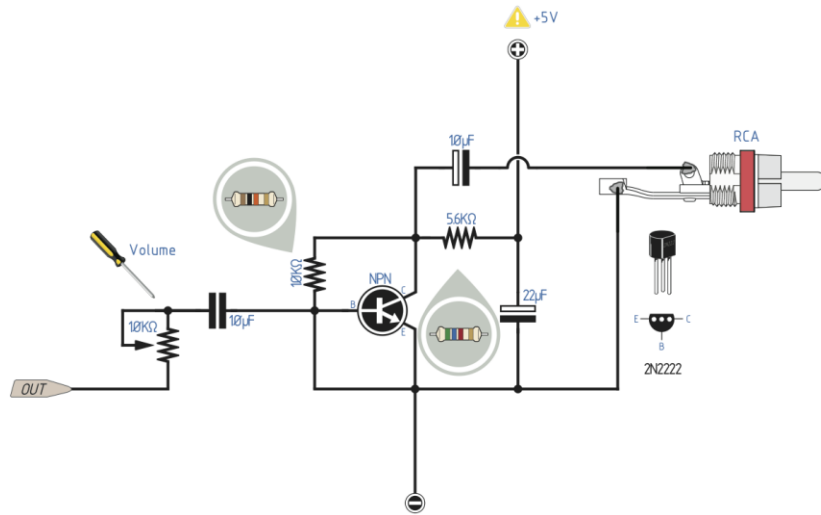

# Connect a Microphone



## Connect a Microphone

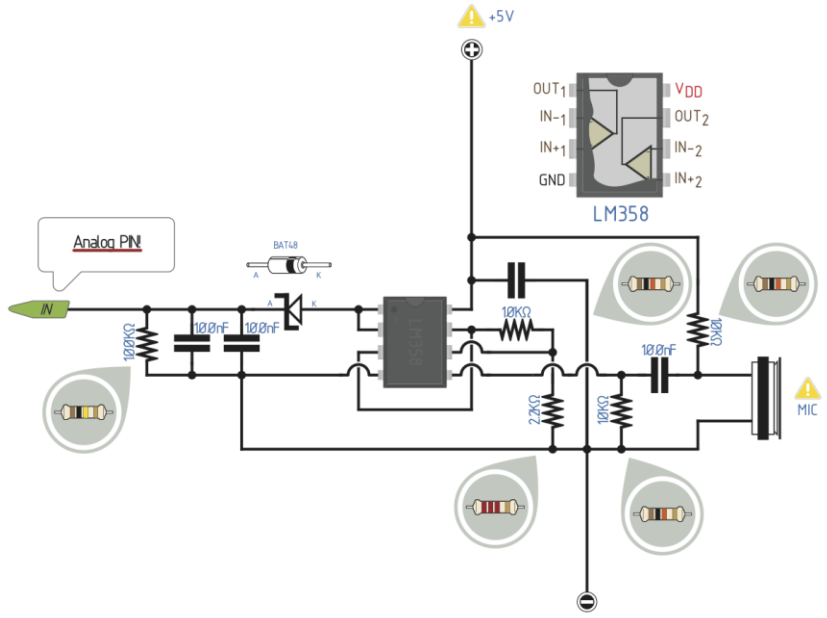





## Connect to Composite Video



### Connect to Composite Video

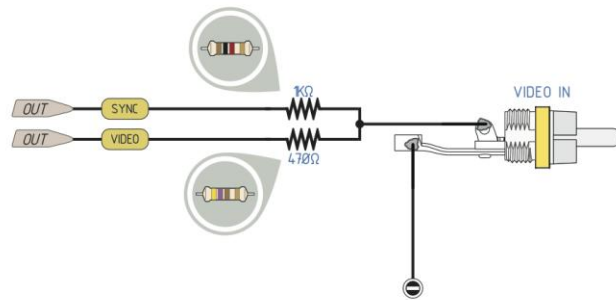

# Connect to VGA



## Connect to VGA

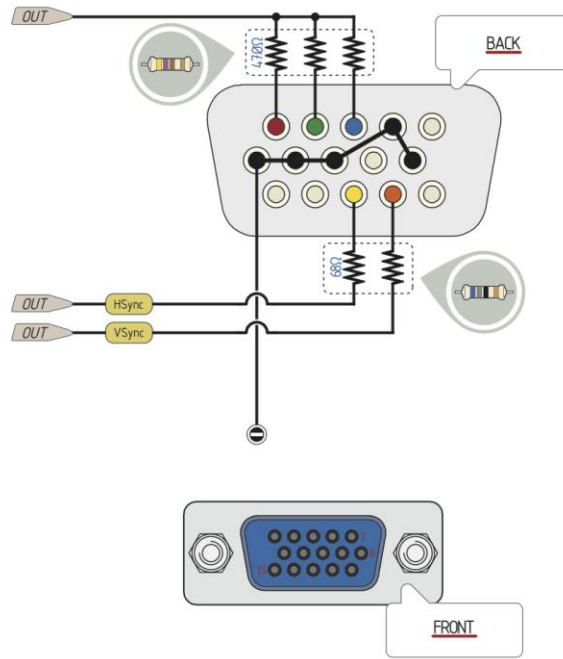

# Zero crossing detect



## Zero crossing detect

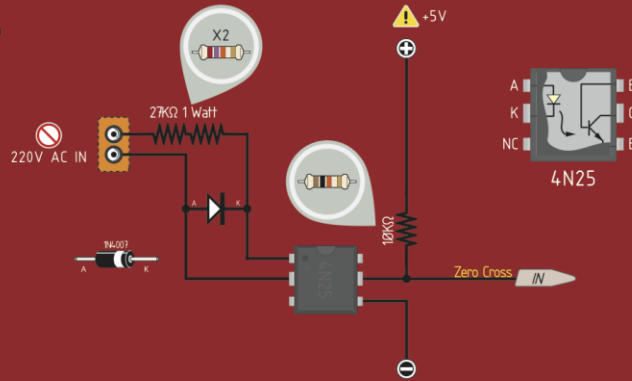

# Connect a Triac



## Connect a Triac

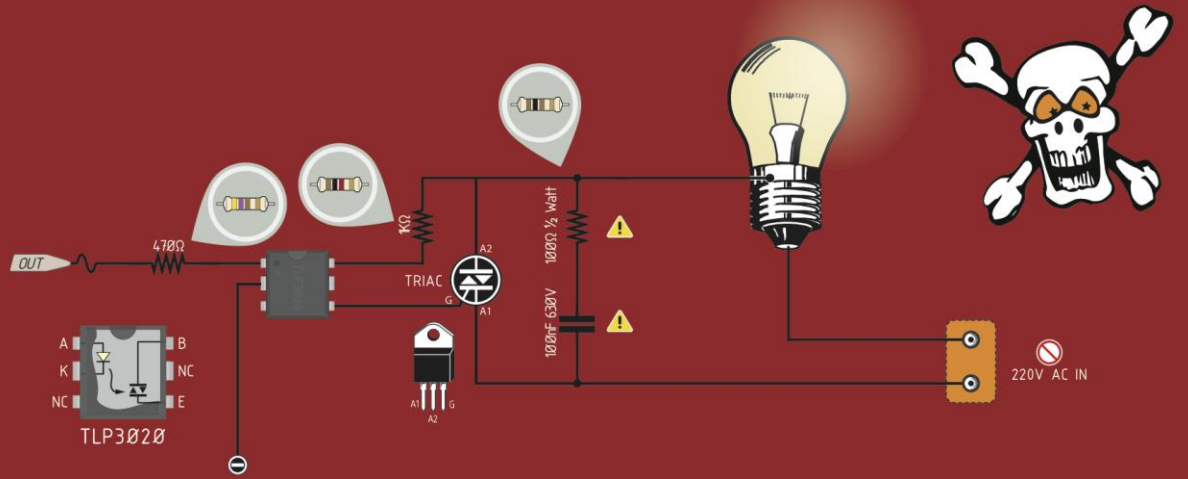

# Connect a Servo



## Connect a Servo

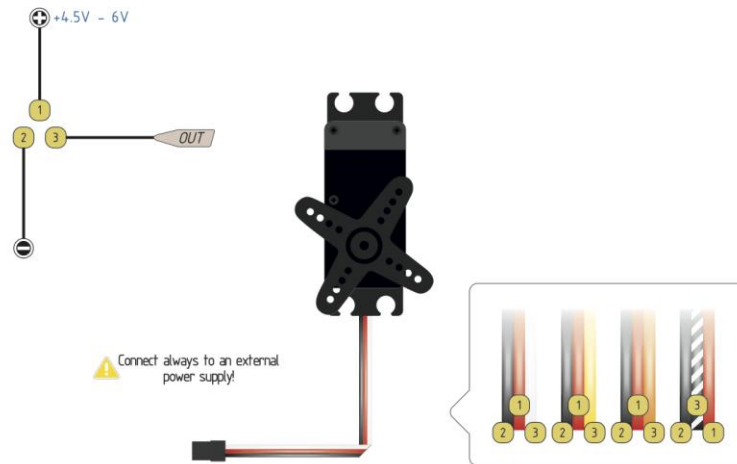

# Connect a IR Sensor



## Connect a IR Sensor

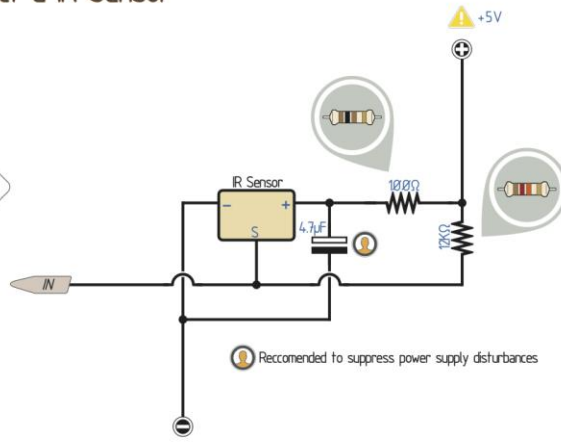
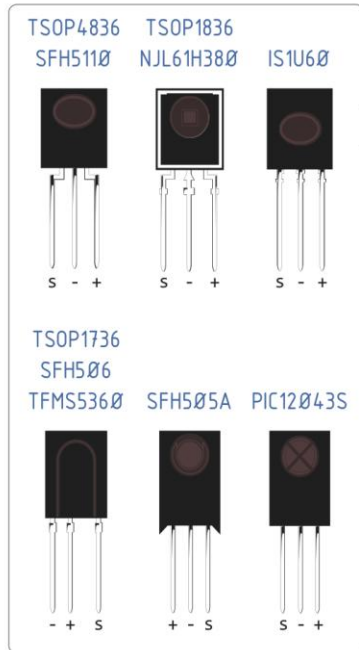

# Connect a IR Emitter



## Connect a IR Emitter

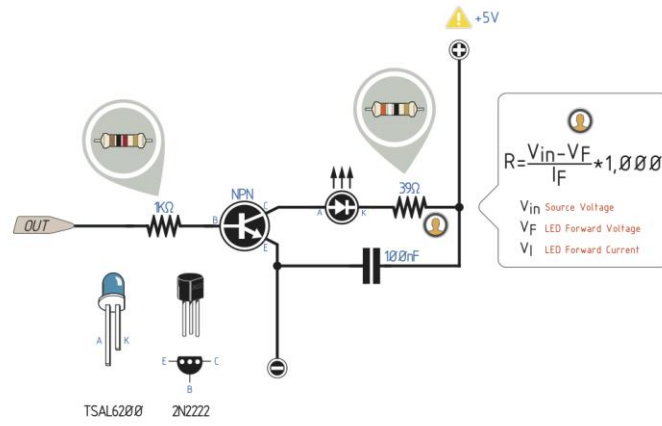

## Bi-Directional Voltage Level Converter 33V to 5V



### Bi-Directional Voltage Level Converter 33V to 5V

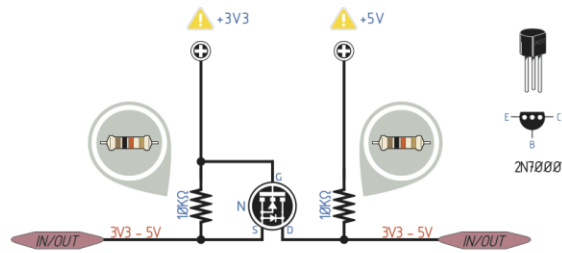



# Bi-Directional Voltage Level Converter 33V to 5V (with Voltage Divider)



## Bi-Directional Voltage Level Converter 3.3V to 5V (with Voltage Divider)

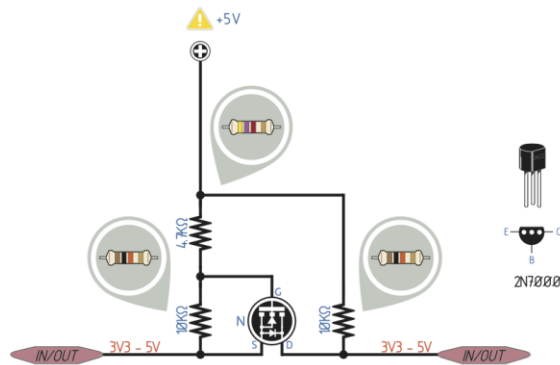

# A simple TTL/CMOS Converter



## A simple TTL/CMOS Converter

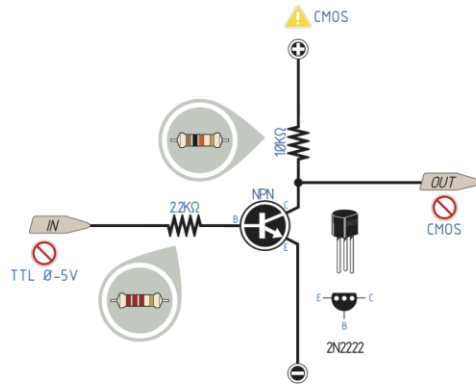

# TTL/CMOS Converter (6 Ports)



## TTL/CMOS Converter (6 ports)

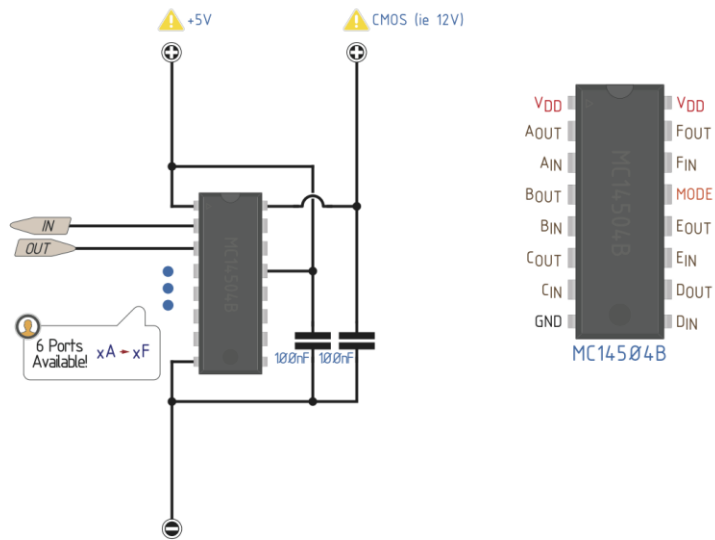

# Connect a SD Card (Simple)



## Connect a SD Card (Simple)

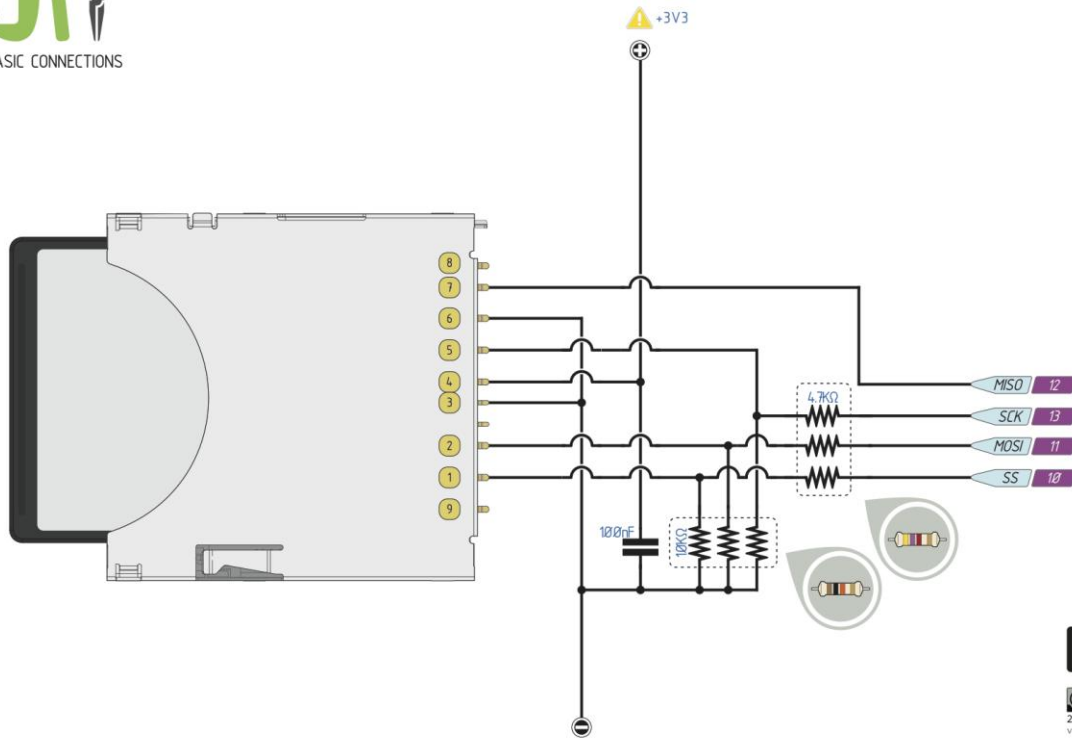

# Connect a SD Card (Advanced)



## Connect a SD Card (Advanced)

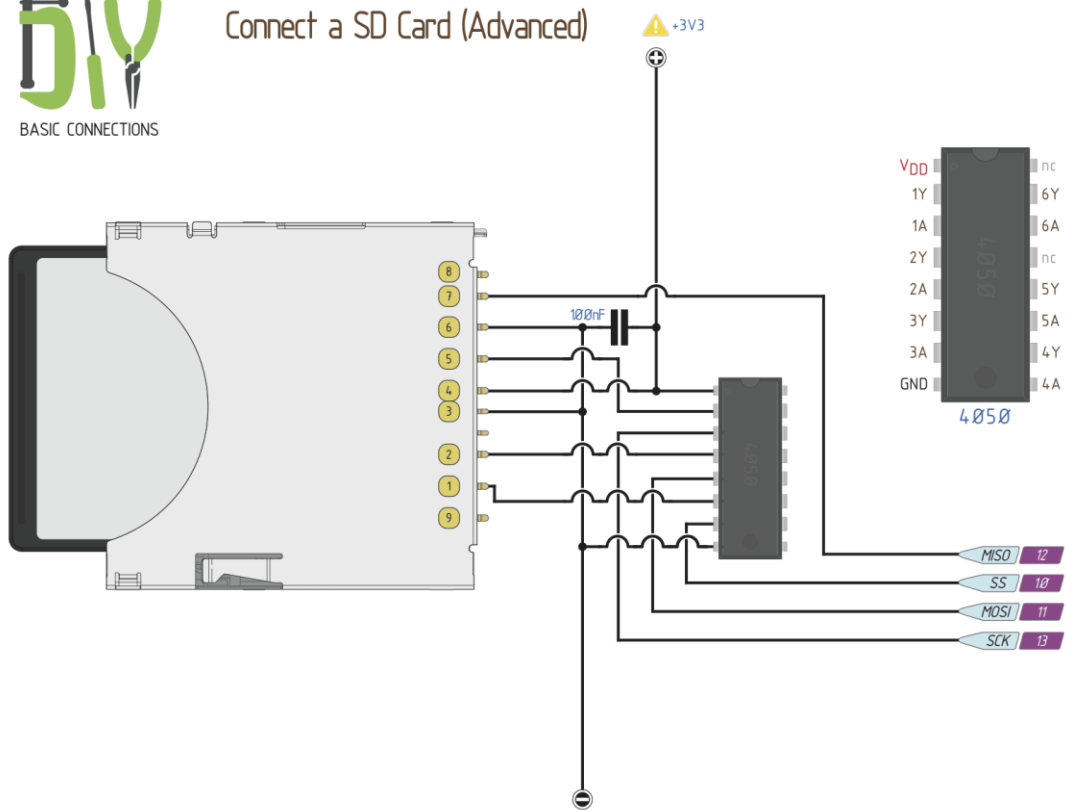

# SD Card Pinout



## SD Card pinout

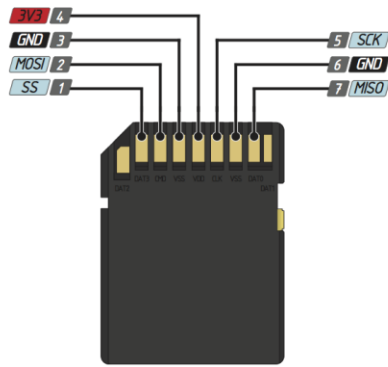

# A Simple Serial interface



## A Simple Serial interface

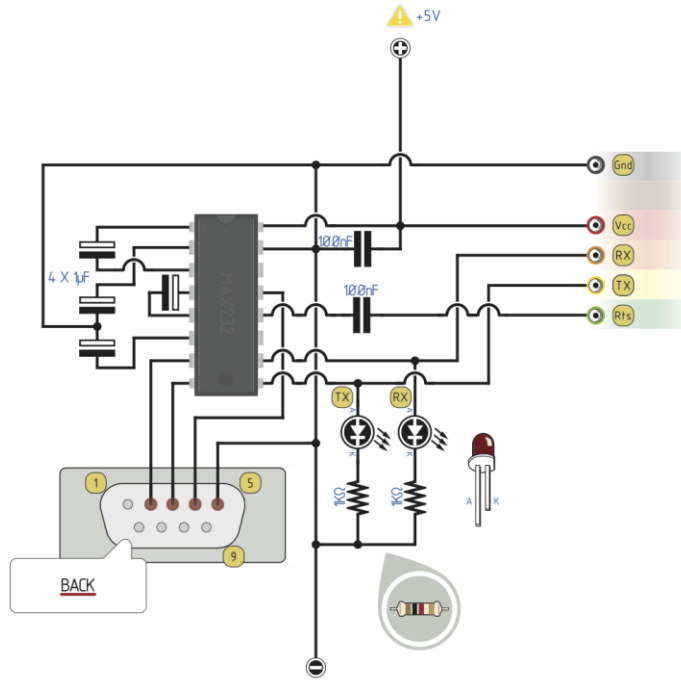
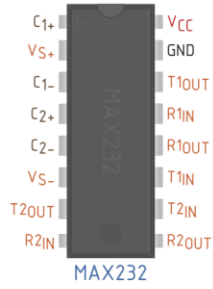

# RS232 Pinout



## RS232 Pinout

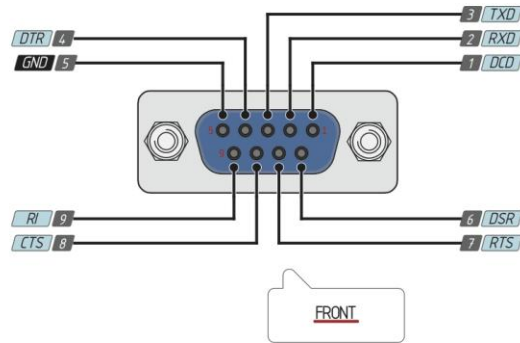



## Connect 2 MPU's



Connect 2 MPU's

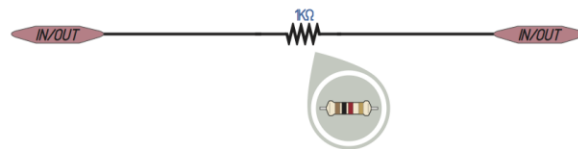

# Protect a I/O Pin



## Protect a I/O Pin

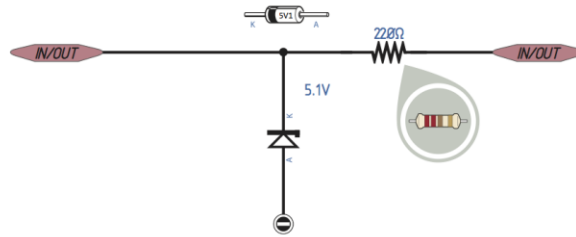

# MDI Interface



## MIDI Interface

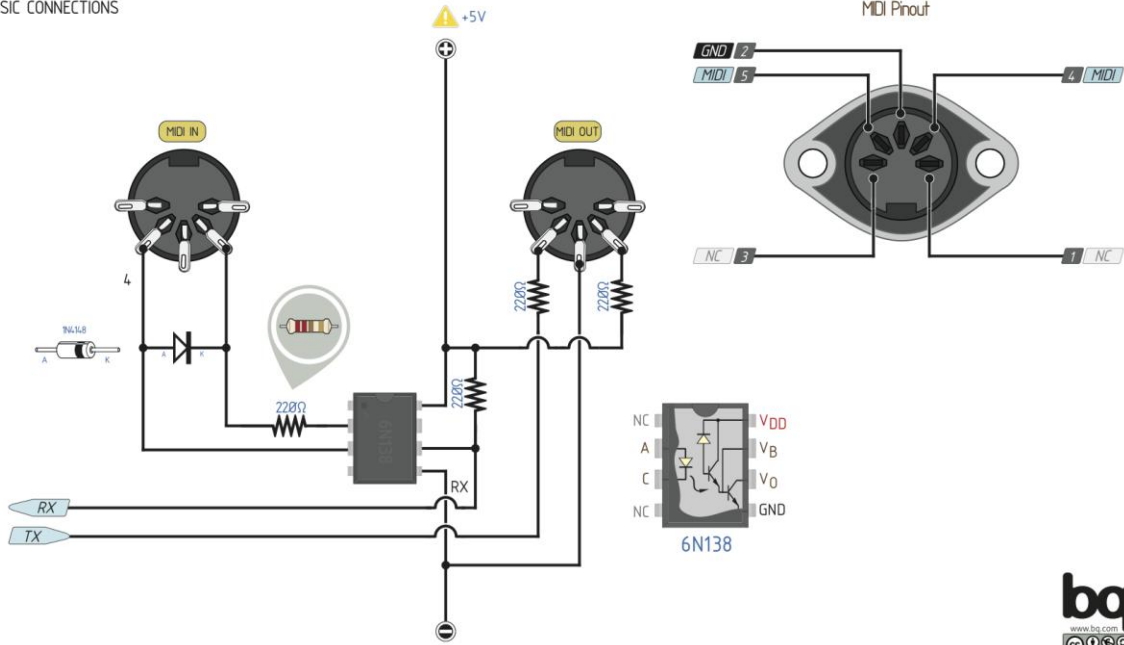

# A simple DMX interface



## A simple DMX Interface

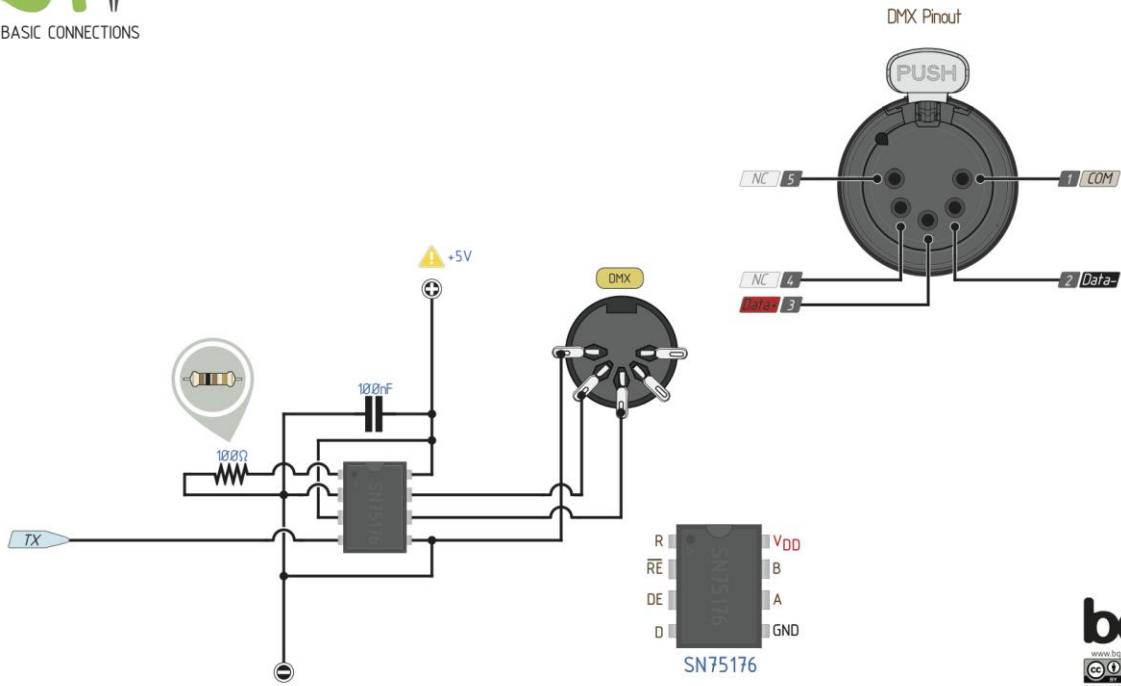

# Driving multiple MIDI Outputs



## Driving multiple MIDI Outputs

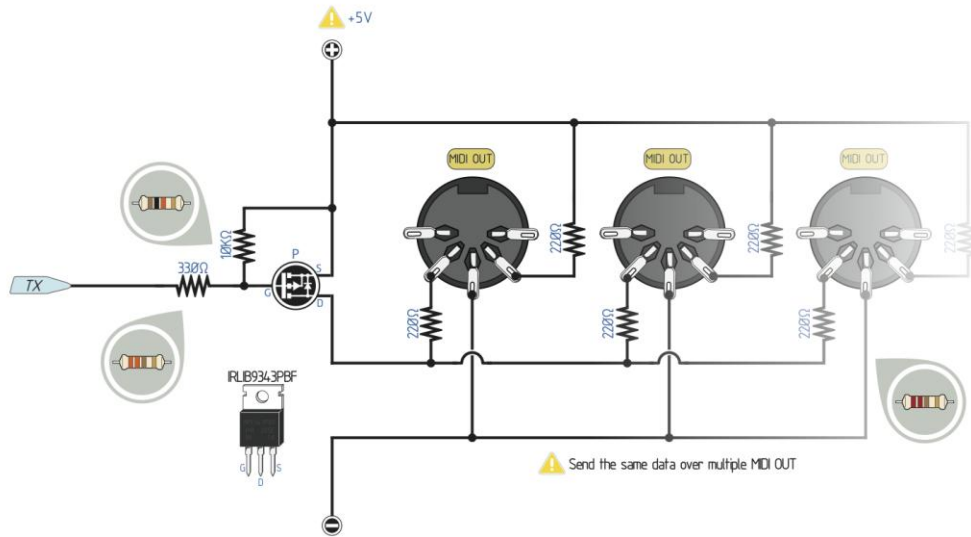

# Connect a SHARP GP2Y0A21 Distance Sensor



## Connect a SHARP GP2Y0A21 Distance Sensor

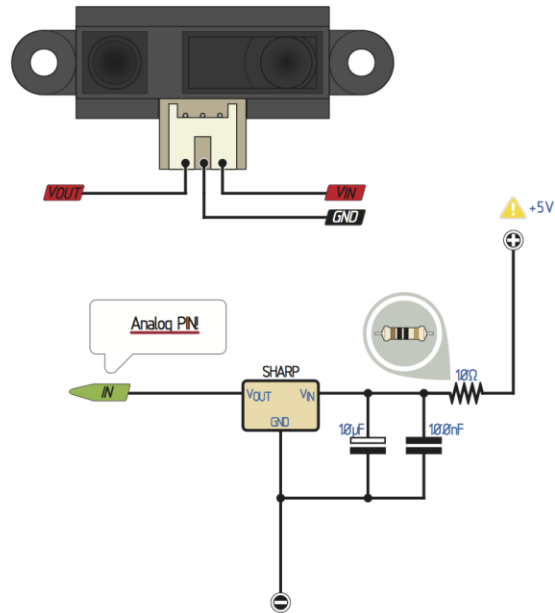

# A simple RS485 Node



## A simple RS485 Node

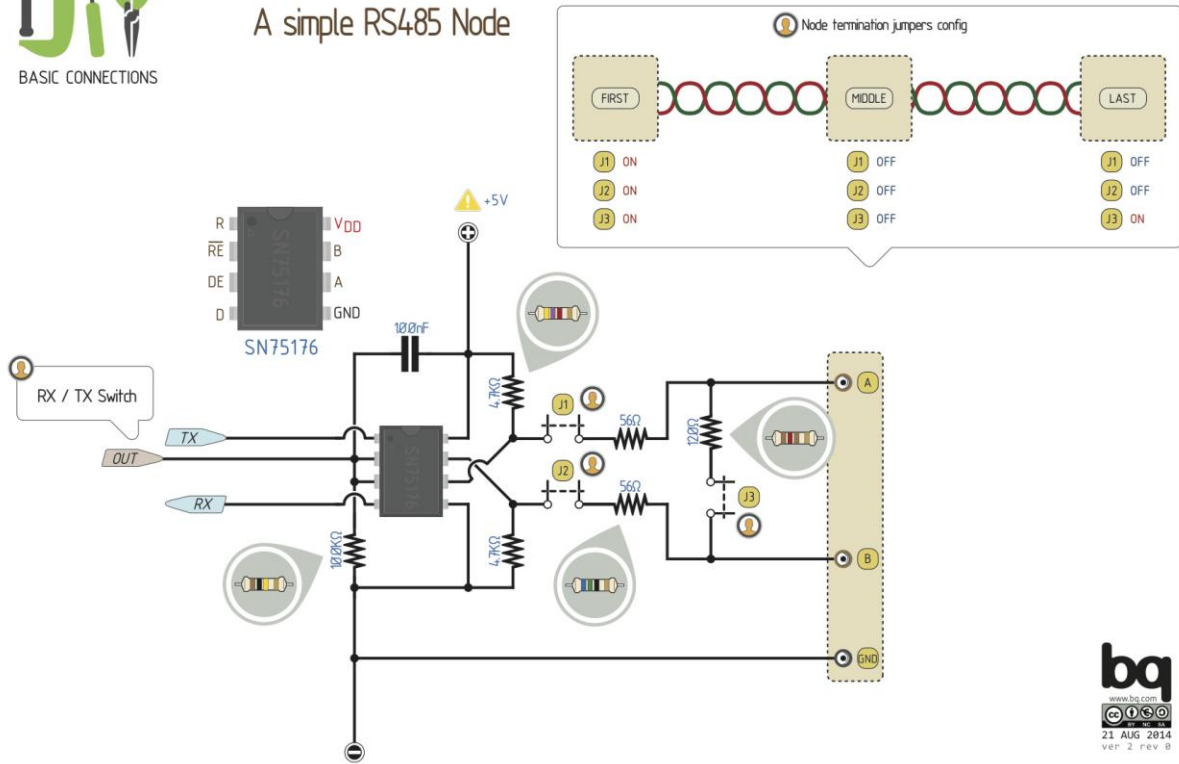

# DIY Board



## DIY Board

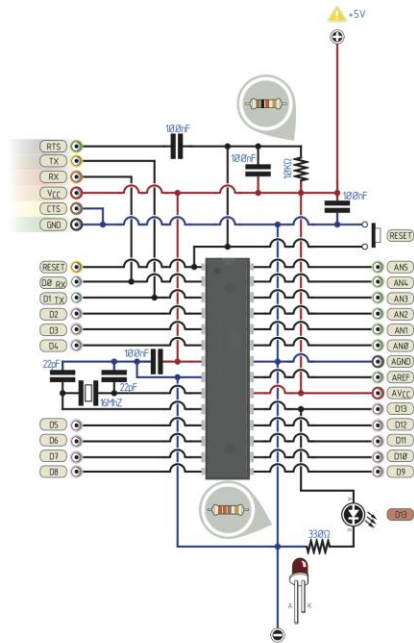



# Simple 5V Power Supply



## Simple 5V Power Supply

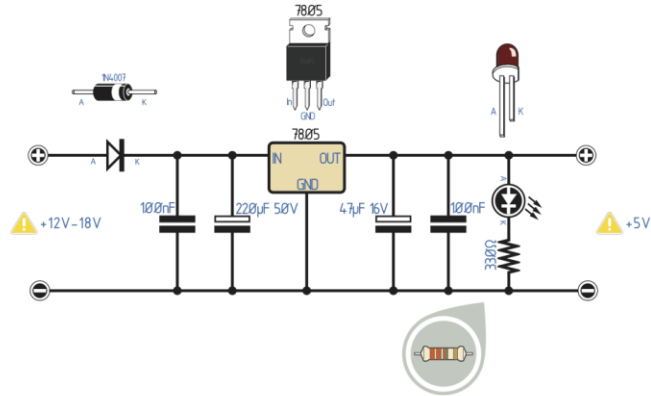

# Simple 3V3 Power Supply



## Simple 3V3 Power Supply

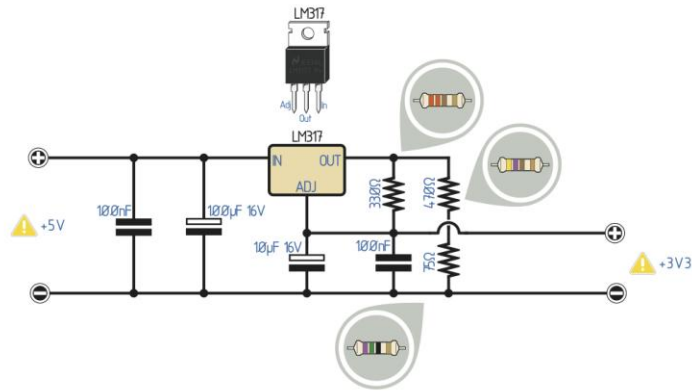

# Connect a RTC



## Connect a RTC

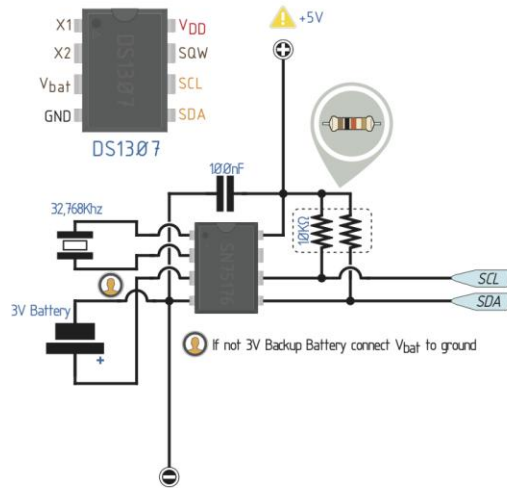

# Conect a EEPROM



## Connect a EEPROM

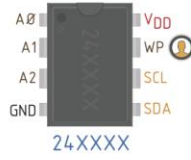

Write disabled when connected to VDD  
Enabled when connected to ground

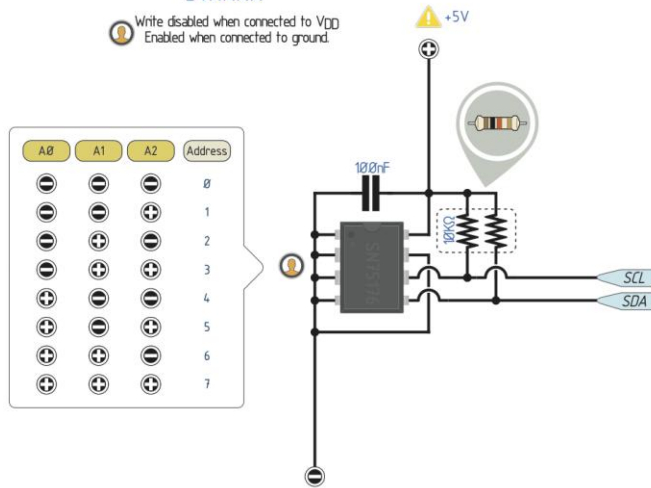

A0	A1	A2	Address
⊖	⊖	⊖	0
⊖	⊖	⊕	1
⊖	⊕	⊖	2
⊖	⊕	⊕	3
⊕	⊖	⊖	4
⊕	⊖	⊕	5
⊕	⊕	⊖	6
⊕	⊕	⊕	7

# EEPROM Wiki



## EEPROM Wiki

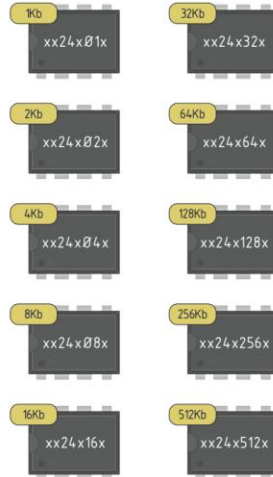

# Hitachi 44780 Compatible pinout



Hitachi 44780 Compatible pinout

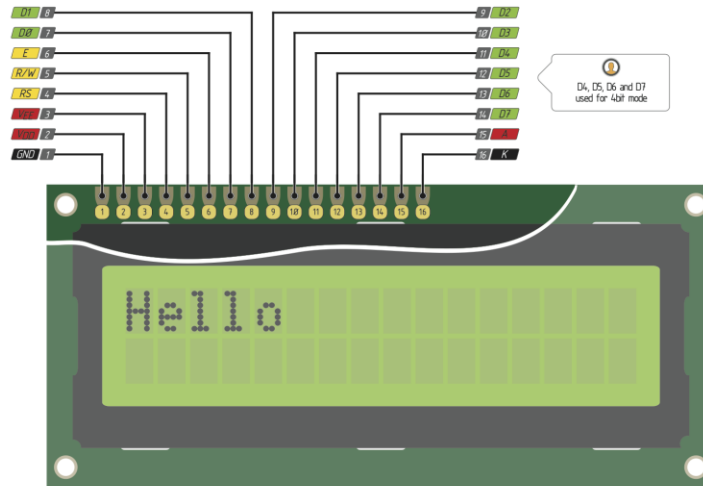

# Connect a LED Hitachi 44780 Compatible



## Connect a LCD Hitachi 44780 Compatible

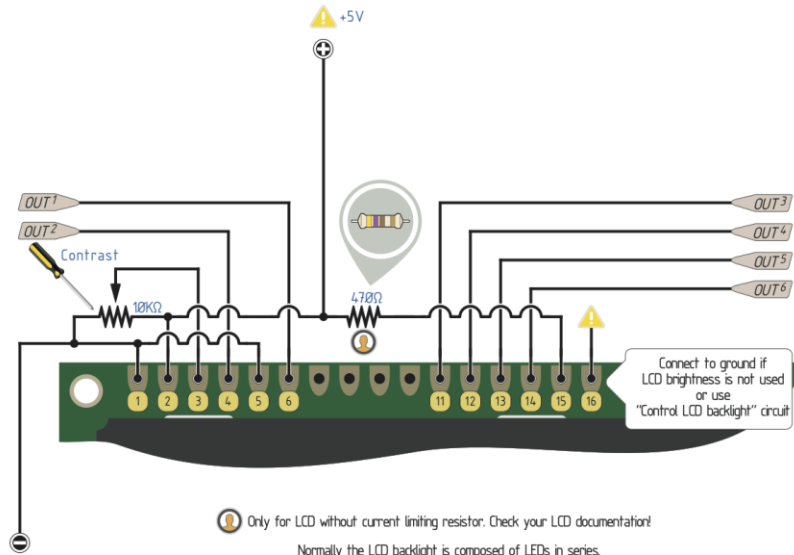

⚠ Only for LCD without current limiting resistor. Check your LCD documentation!

Normally the LCD backlight is composed of LEDs in series. The total voltage drop across these LEDs is typically 4.2 V and the recommended current through the LEDs is 128 mA. You should use a current limiting resistor  $R_{LIMIT}$  where:

$$R_{LIMIT} = \frac{(V_{BACKLIGHT} - 4.2)}{0.128}$$

# Connect a LED Hitachi 44780 Compatible via I2C



Connect a LCD Hitachi 44780 Compatible via I2C

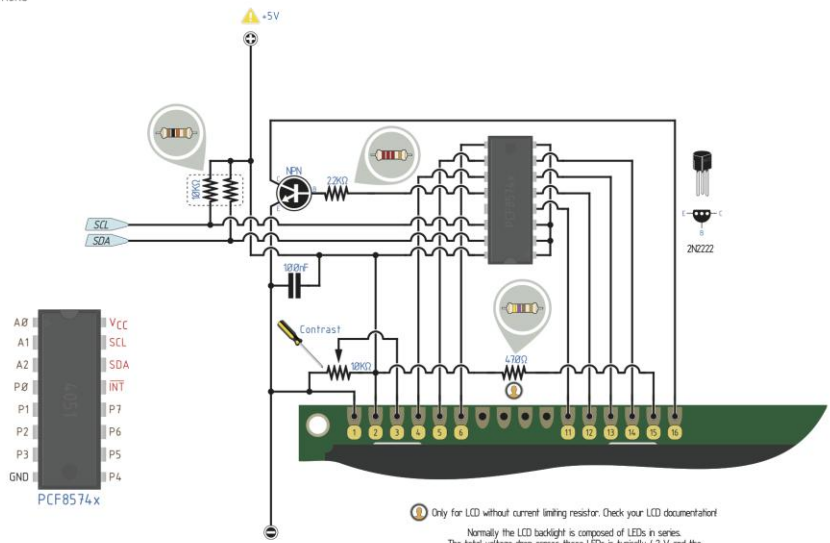

ⓘ Only for LCD without current limiting resistor. Check your LCD documentation!

Normally the LCD backlight is composed of LEDs in series.  
The total voltage drop across these LEDs is typically 4.2 V and the recommended current through the LEDs is 120 mA.  
You should use a current limiting resistor  $R_{LIMIT}$  where

$$R_{LIMIT} = \frac{(V_{BACKLIGHT} - 4.2)}{0.12A}$$



# Control LCD Backlight



## Control LCD backlight

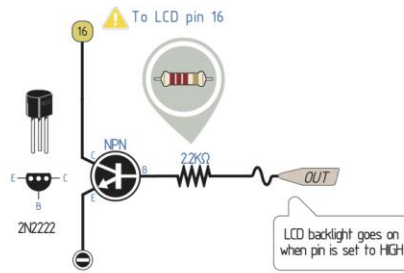

# 7 segments Display



## 7 segments display

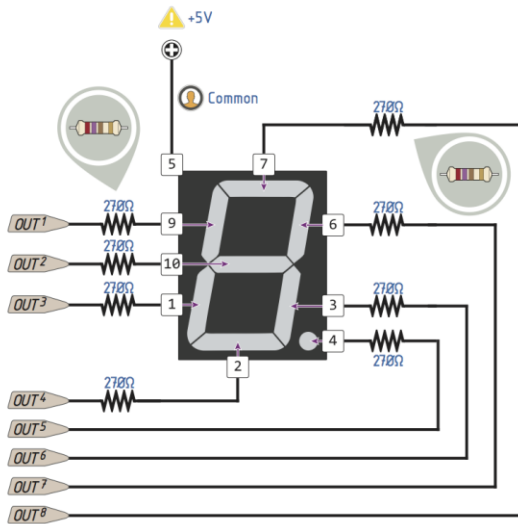

# Connect a Nokia LCD



## Connect a Nokia LCD

